

ITEM NO.	PART NUMBER	DESCRIPTION	QTY.
10	MACH-004181	BODY, CTS, CI31	1
20	MACH-004248	Cap, CTS, CI31	1
30	MACH-054203	Stem, CTS, CI31-E1.0	1
40	SEAL-005436	CI31-ORING 109	1
50	SEAL-005438	CI31-ORING 216	1
60	MACH-004301	Nose, CTS, CI31-SAE-D	1
70	SEAL-004793	Seal, CTS, CI31-SAE-D	1
80	MACH-004433	Washer, CTS, CI31-SAE-D	1
90	MACH-004578	Spacer Extension, CTS, CI31	1

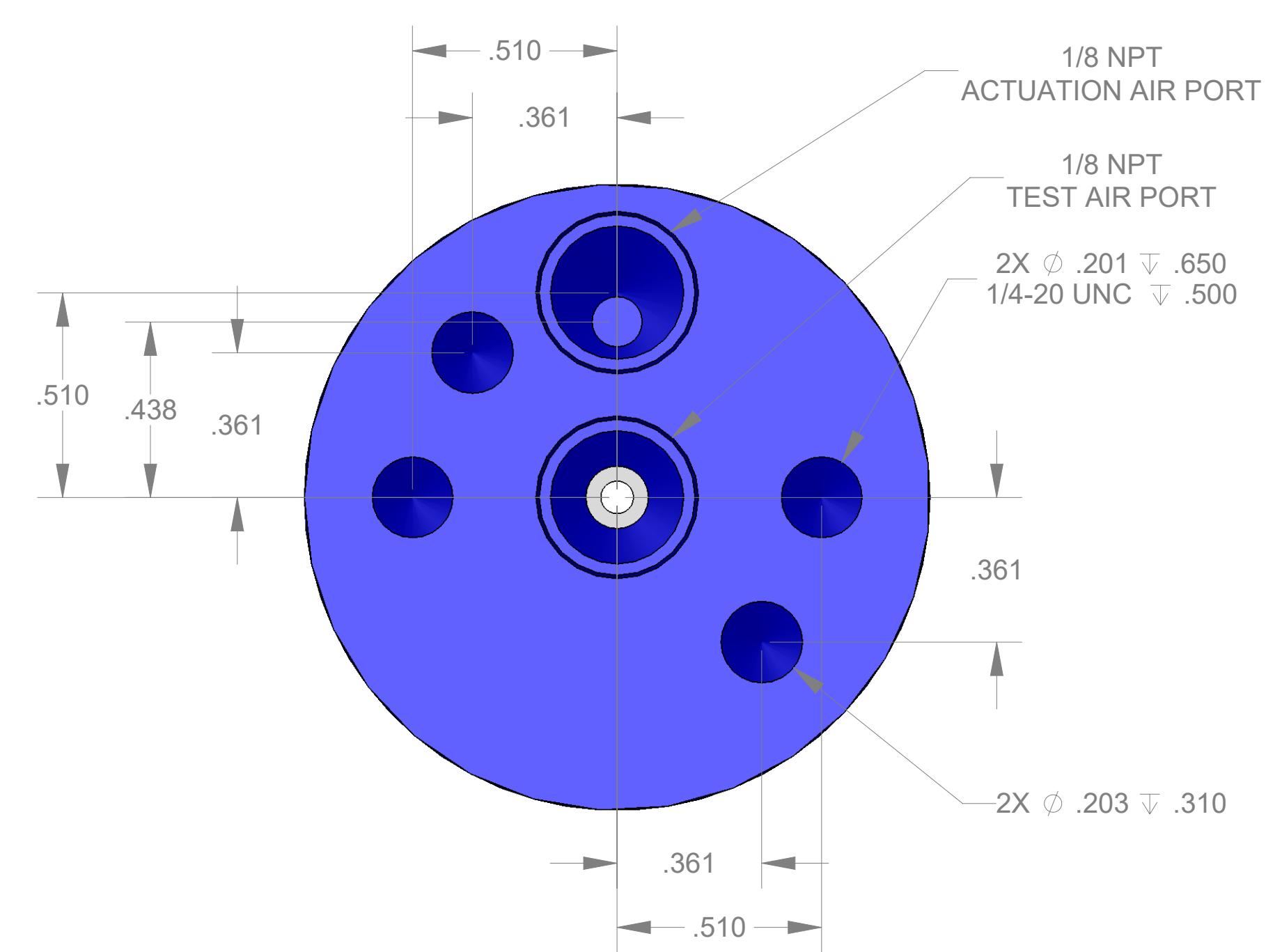

REVISIONS			
REV.	DESCRIPTION	DATE	APPROVED
A	Initial Release	02-05-2026	KM
B	Nose material changed from brass to 316 stainless steel	04-06-2026	KM

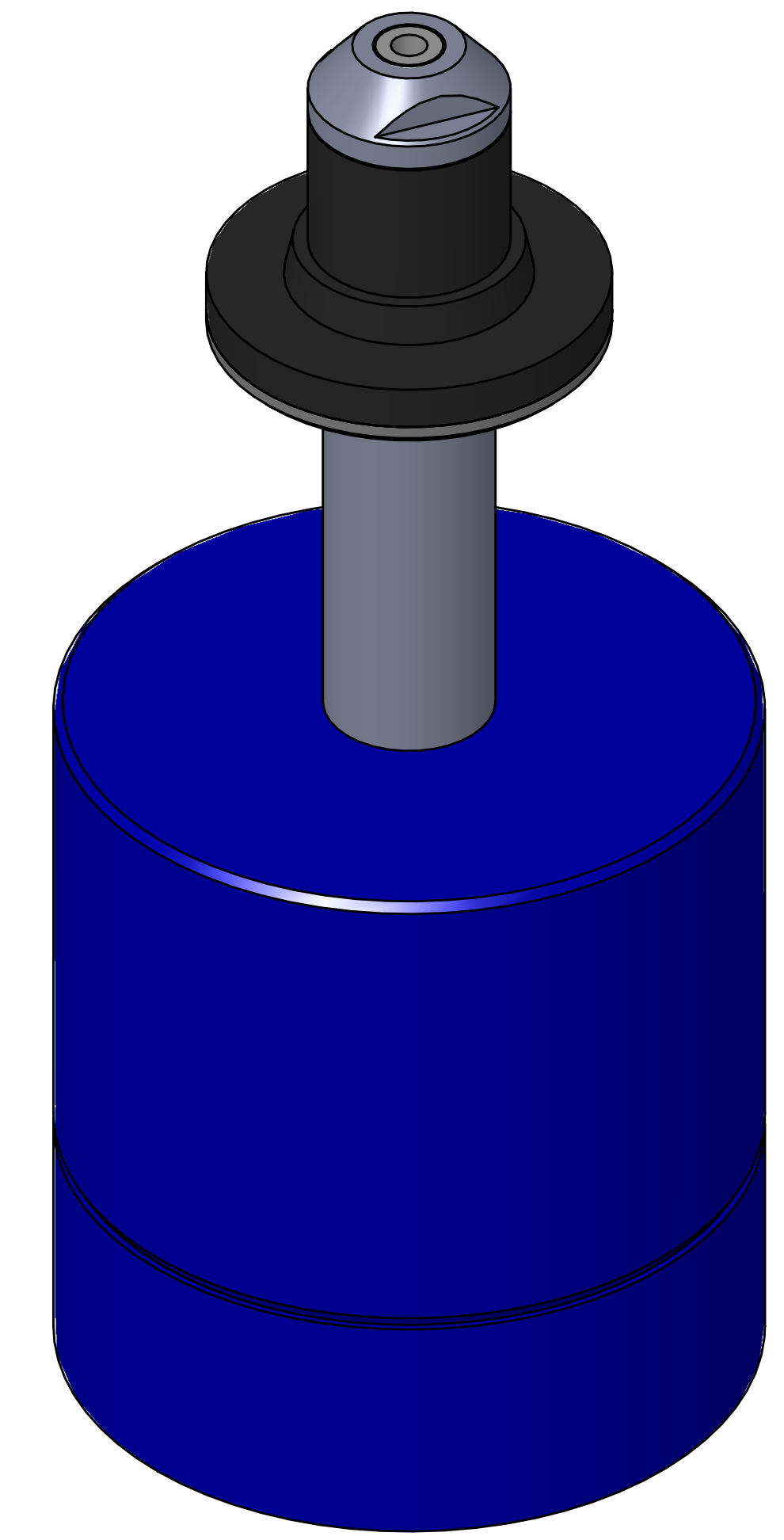
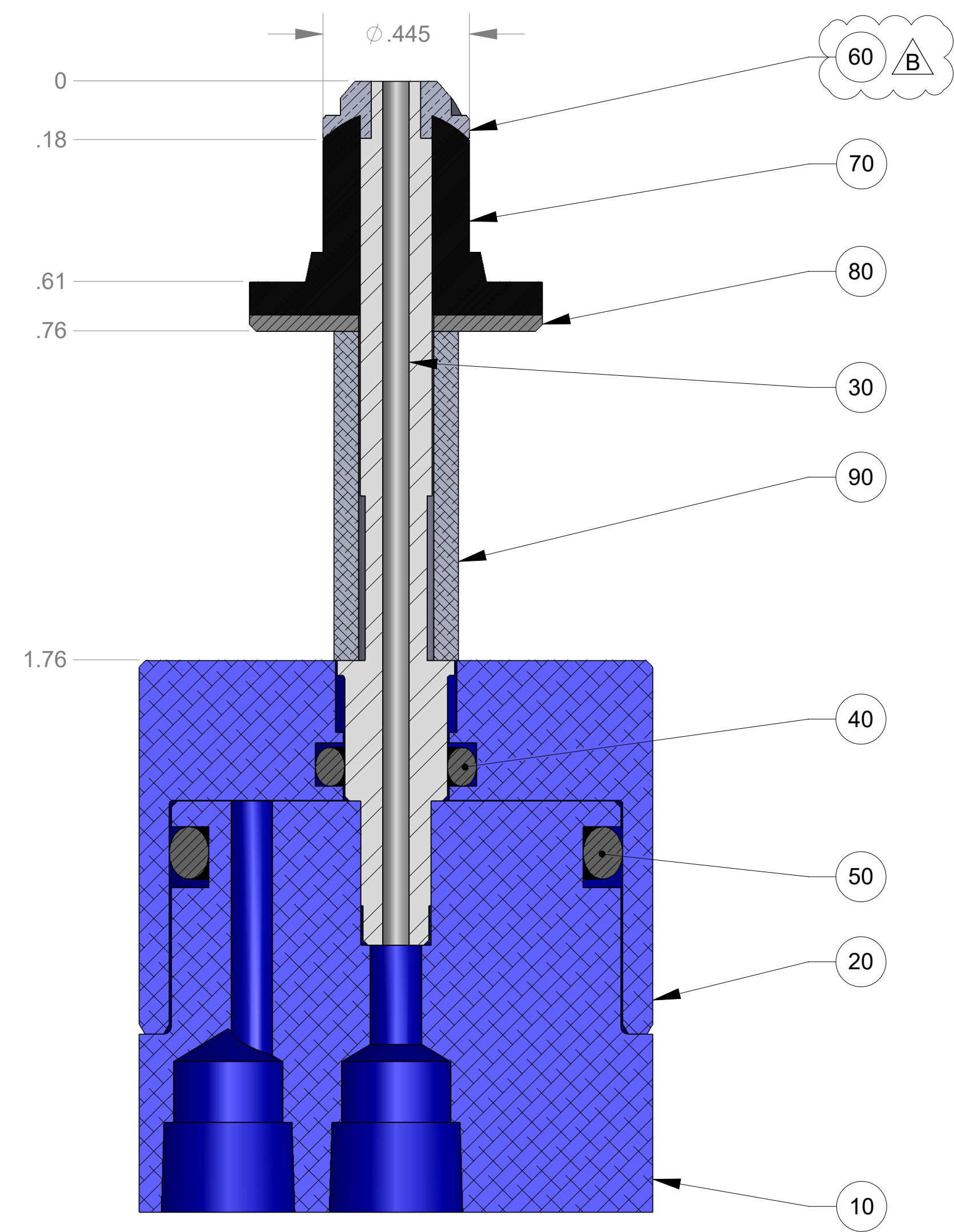
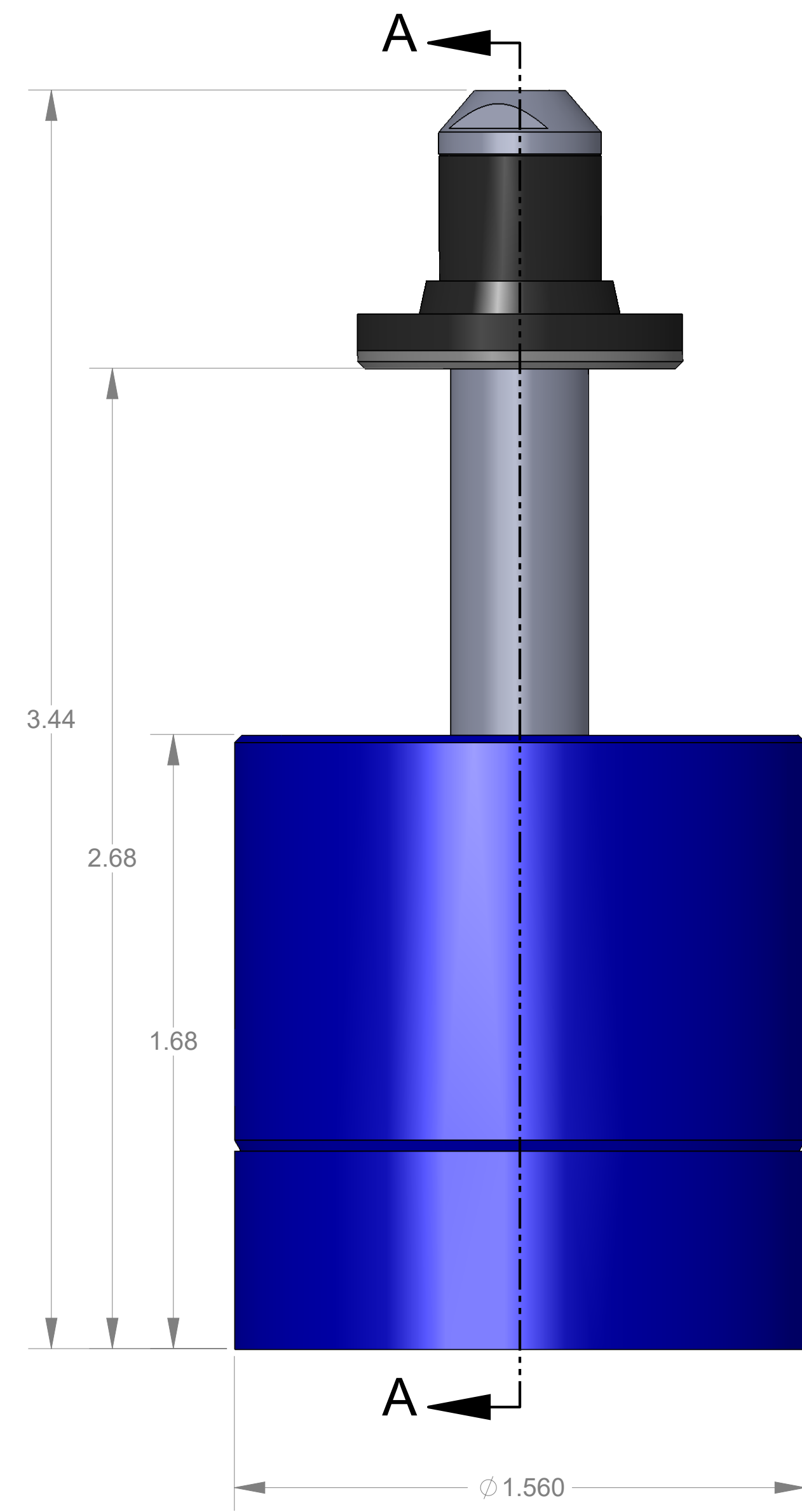

SIZE	DESCRIPTION	REV
D	Connect Assembly, CTS, CI31-SAE-0500-E1.0	B
PART NUMBER	CTSC-002382	
DATE	7/19/05	DRAWN BY: KM CHECKED BY: KM SHEET 1 OF 1

FILE LOCATION: C:\PDM\PDM\R&D Product Development\CTS Connects\C1\Connect Assembly\Standard\CI31\1in Stem Extension\CTSC-002382

Monday, April 6, 2026