

ITEM NO.	PART NUMBER	DESCRIPTION	QTY.
10	MACH-004180	BODY, CTS, CI30	1
20	MACH-004247	Cap, CTS, CI30	1
30	MACH-004276	Nose, CTS, CI30-AA	1
40	MACH-004424	Washer, CTS, CI30-SAE-0375	1
50	MACH-004612	Stem, CTS, CI30	1
60	SEAL-004746	Seal, CTS, CI30-SAE-0375	1
70	SEAL-005446	CI30-ORING 009	1
80	SEAL-005447	CI30-ORING 119	1

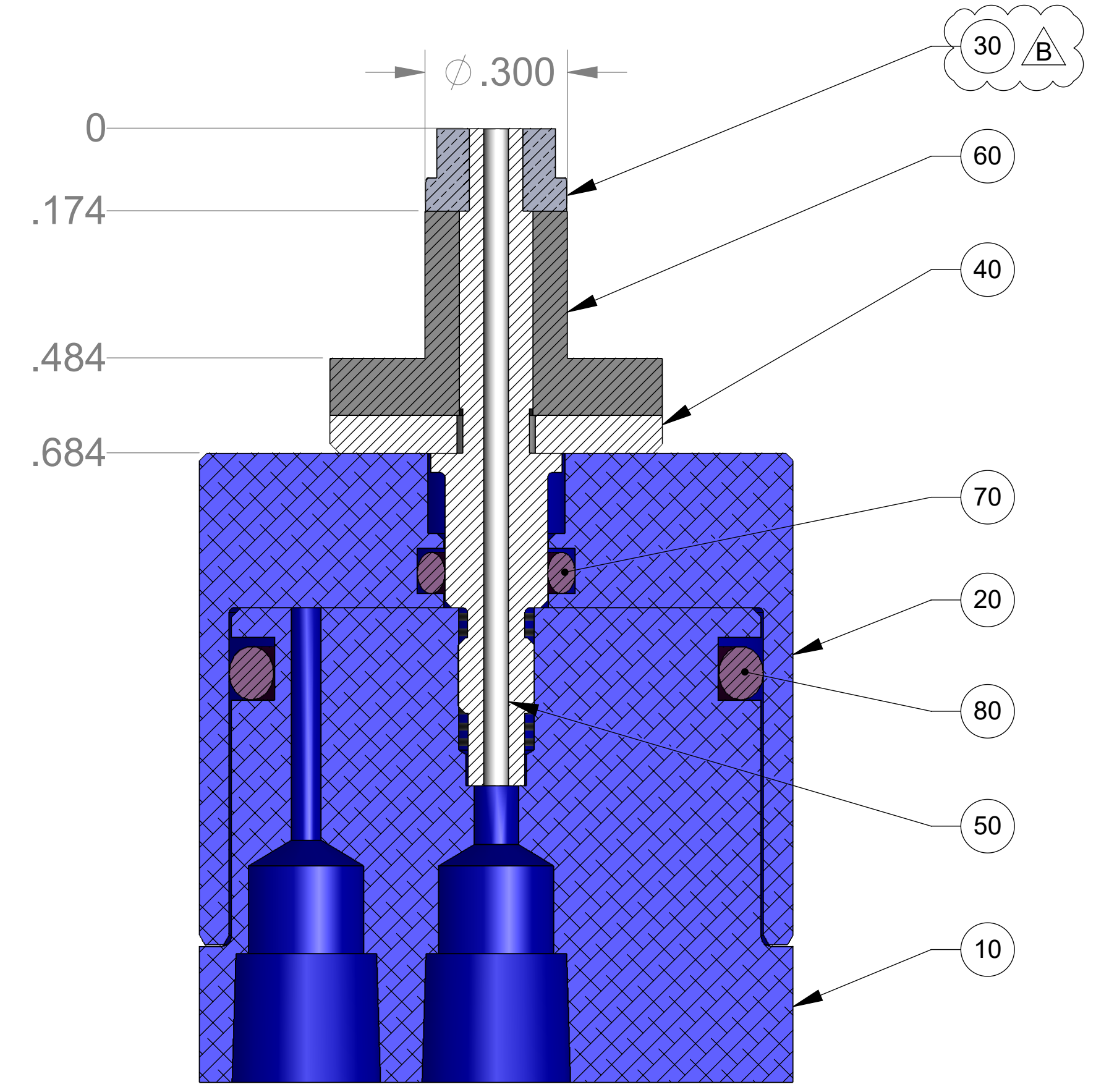

SECTION A-A
SCALE 4 : 1

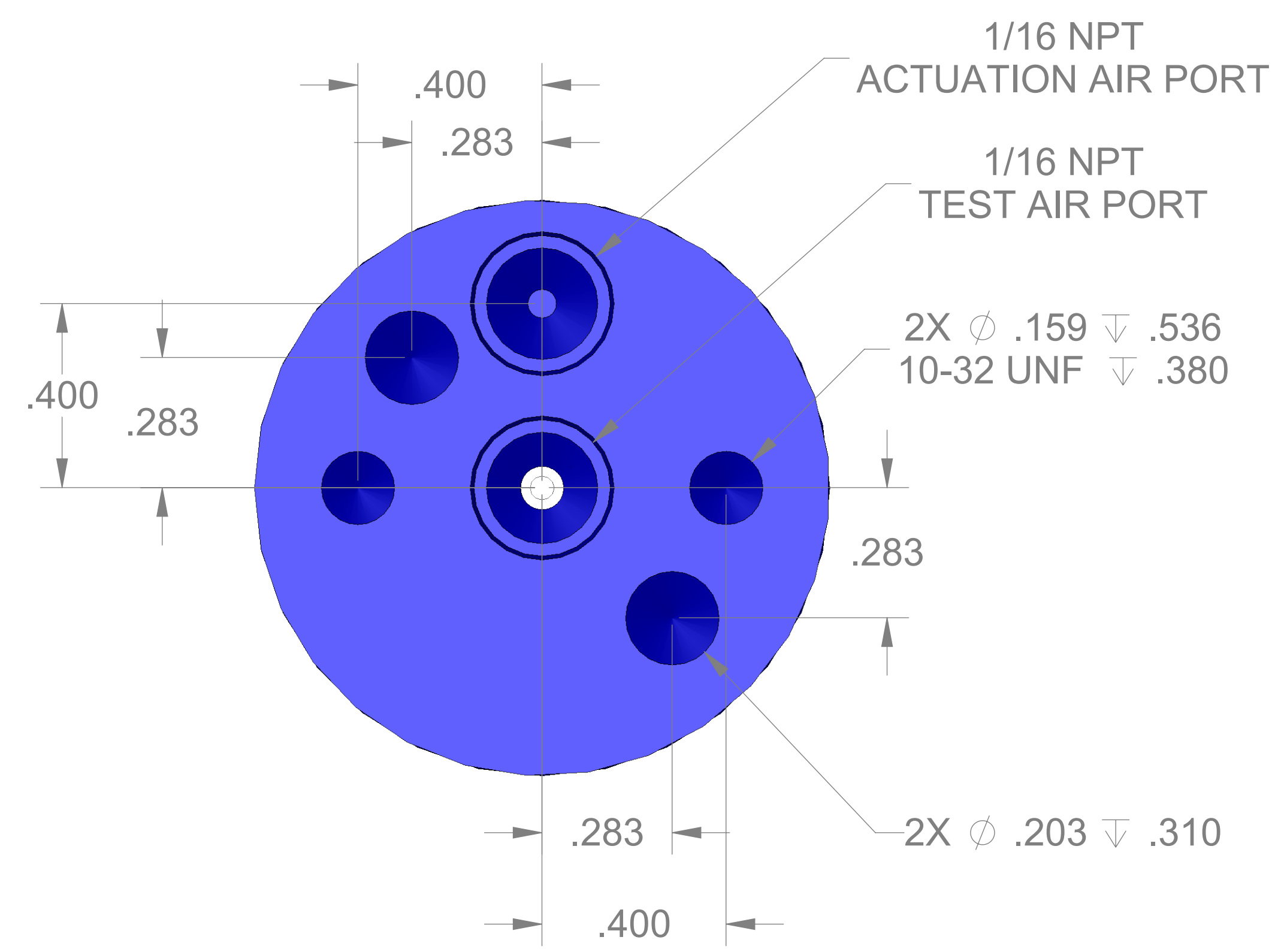

REVISIONS			
REV.	DESCRIPTION	DATE	APPROVED
A	Initial Release	07-01-2015	JAW
B	Nose material changed from brass to 316 stainless steel	12-15-2025	KM



SIZE	DESCRIPTION	REV
D	Connect Assembly, CTS, CI30-SAE-0375	B
PART NUMBER		REV
CTSC-002353		B
DATE	DRAWN BY	CHECKED BY
7/01/15		KM
SHEET		OF
1		1

FILE LOCATION: C:\PDM\PDM\R&D Product Development\CTS Connects\CI\Connect Assembly\CI30\CTSC-002353

Monday, December 15, 2025