

ITEM NO.	PART NUMBER	DESCRIPTION	QTY.
10	MACH-004185	Body, CTS, CI35	1
20	MACH-004252	Cap, CTS, CI35	1
30	MACH-054222	Stem, CTS, CI35-E3.0	1
40	SEAL-005449	CI35-ORING 210	1
50	SEAL-005443	CI35-ORING 337	1
60	MACH-004343	Nose, CTS, CI35-M42	1
70	MACH-004463	Washer, CTS, CI35-M42	1
80	MACH-004592	Spacer Extension, CTS, CI35	3
90	SEAL-004930	Seal, CTS, CI35-M42	1

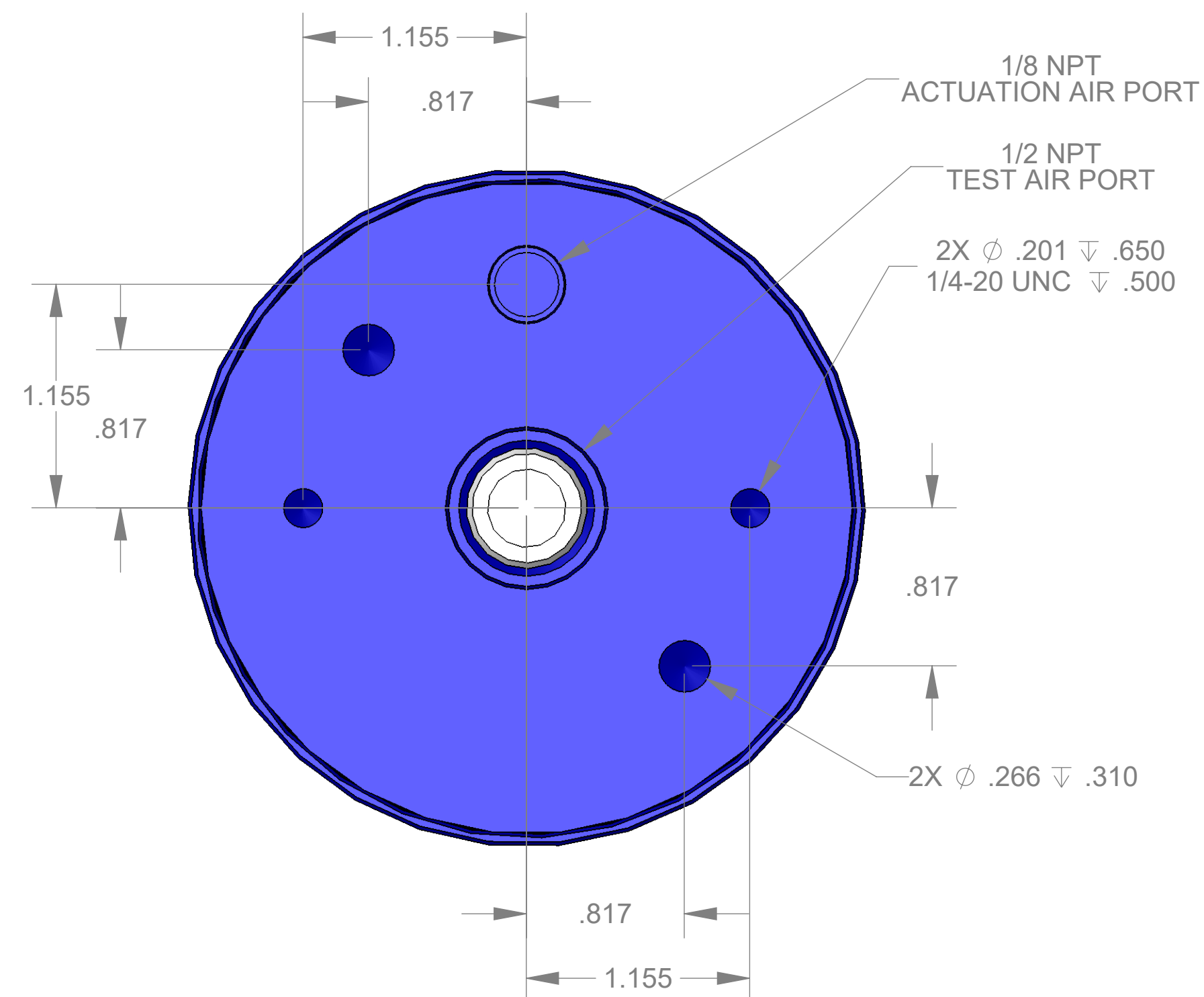

SECTION A-A
SCALE 3 : 2

REVISIONS			
REV.	DESCRIPTION	DATE	APPROVED
A	Initial Release	04-06-2026	KM
B	Nose material changed from brass to 316 stainless steel	04-06-2026	KM

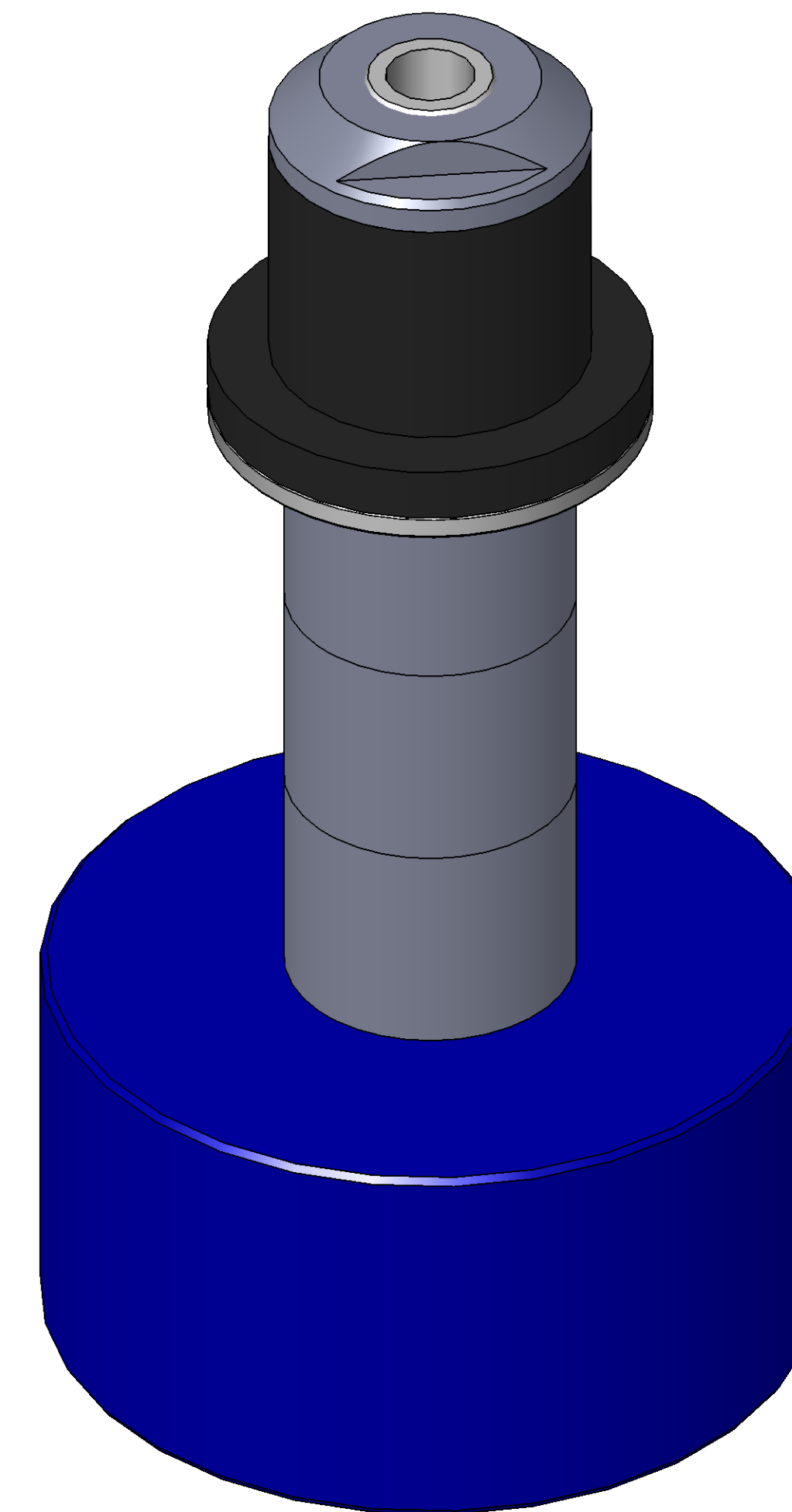

10100 PROGRESS WAY HARRISON, OH 45030

SIZE	DESCRIPTION	REV
D	Connect Assembly, CTS, CI35-M42-E3.0	B
PART NUMBER	CTSC-002300	
DATE	11/04/05	DRAWN BY: KM CHECKED BY: KM SHEET 1 OF 1