

ITEM NO.	PART NUMBER	DESCRIPTION	QTY.
10	MACH-004183	Body, CTS, CI33	1
20	MACH-004250	Cap, CTS, CI33	1
30	MACH-004629	Stem, CTS, CI33	1
40	SEAL-005437	CI33-ORING 113	1
50	SEAL-005441	CI33-ORING 225	1
60	MACH-004322	Nose, CTS, CI33-M26	1
70	SEAL-004864	Seal, CTS, CI33-M26	1
80	MACH-004447	Washer, CTS, CI33-M26	1

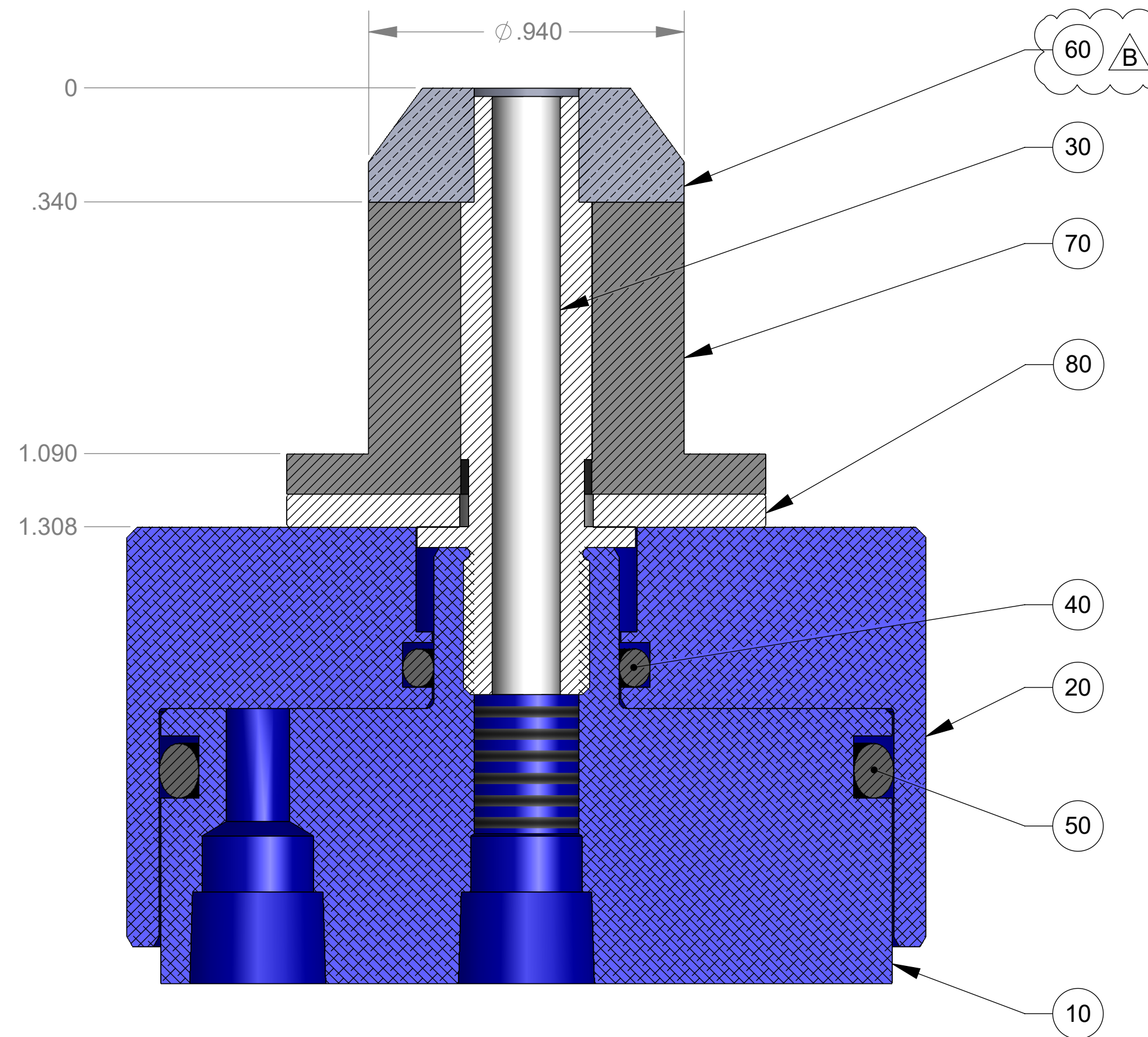

SECTION A-A
SCALE 3 : 1

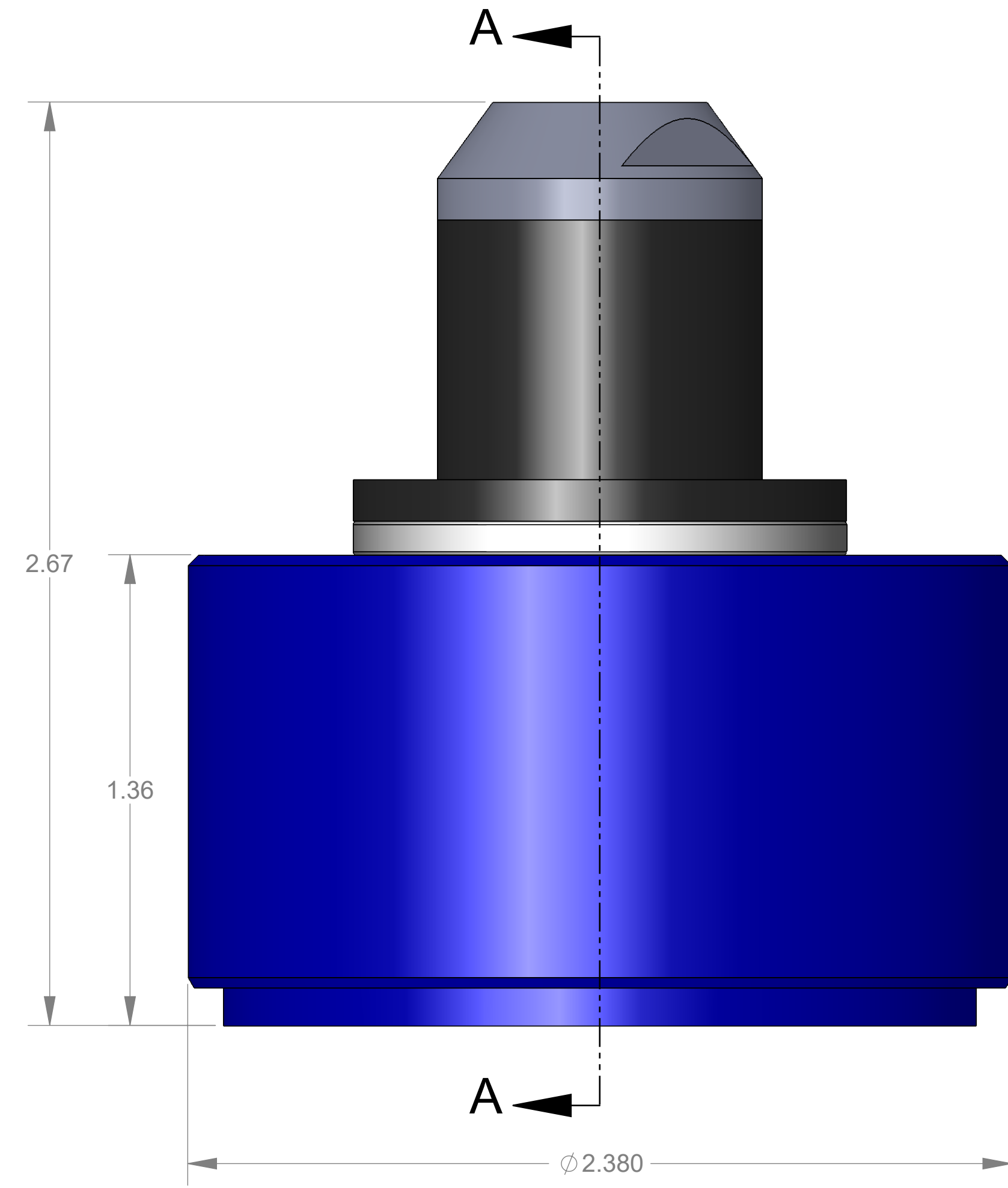
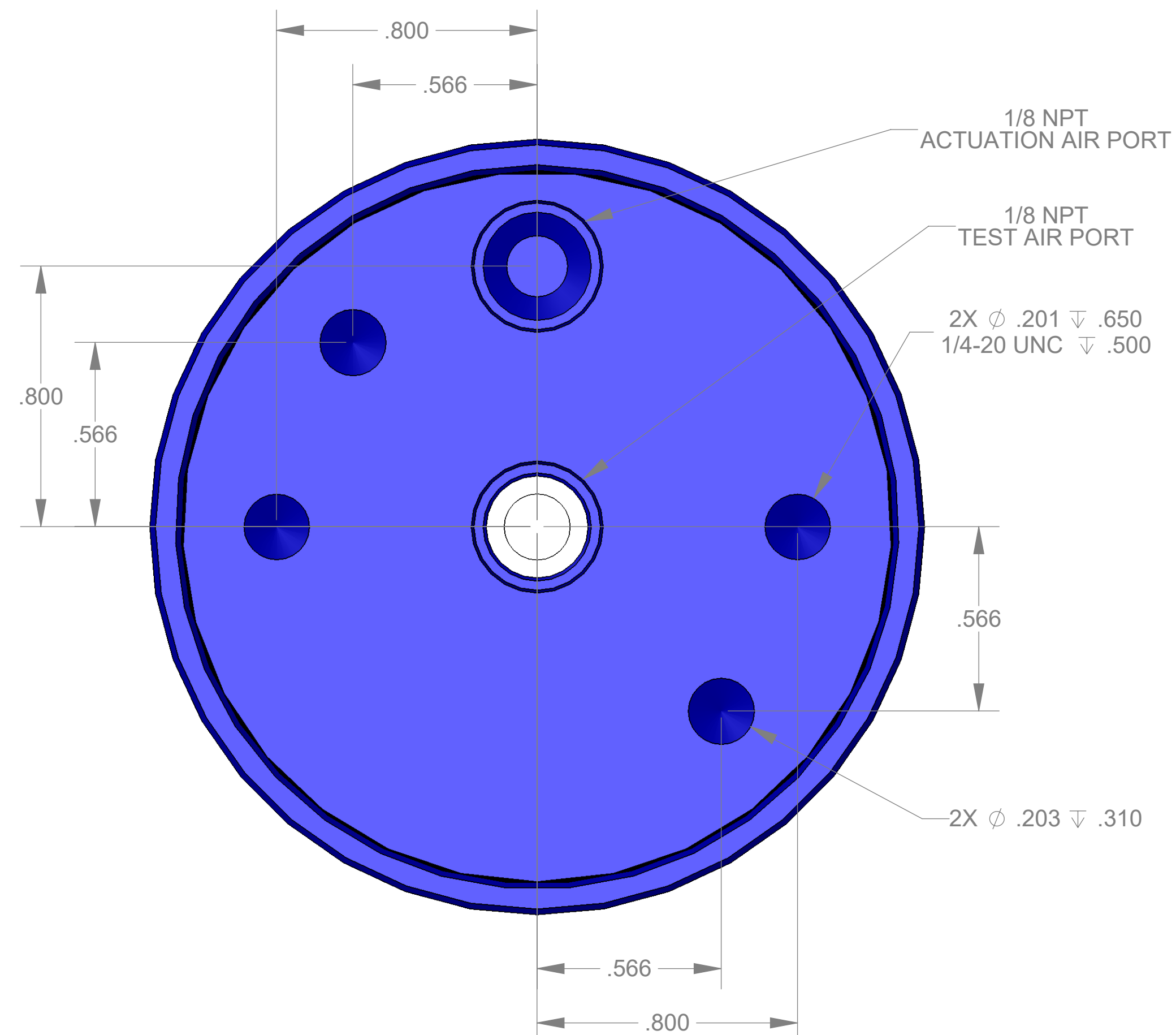
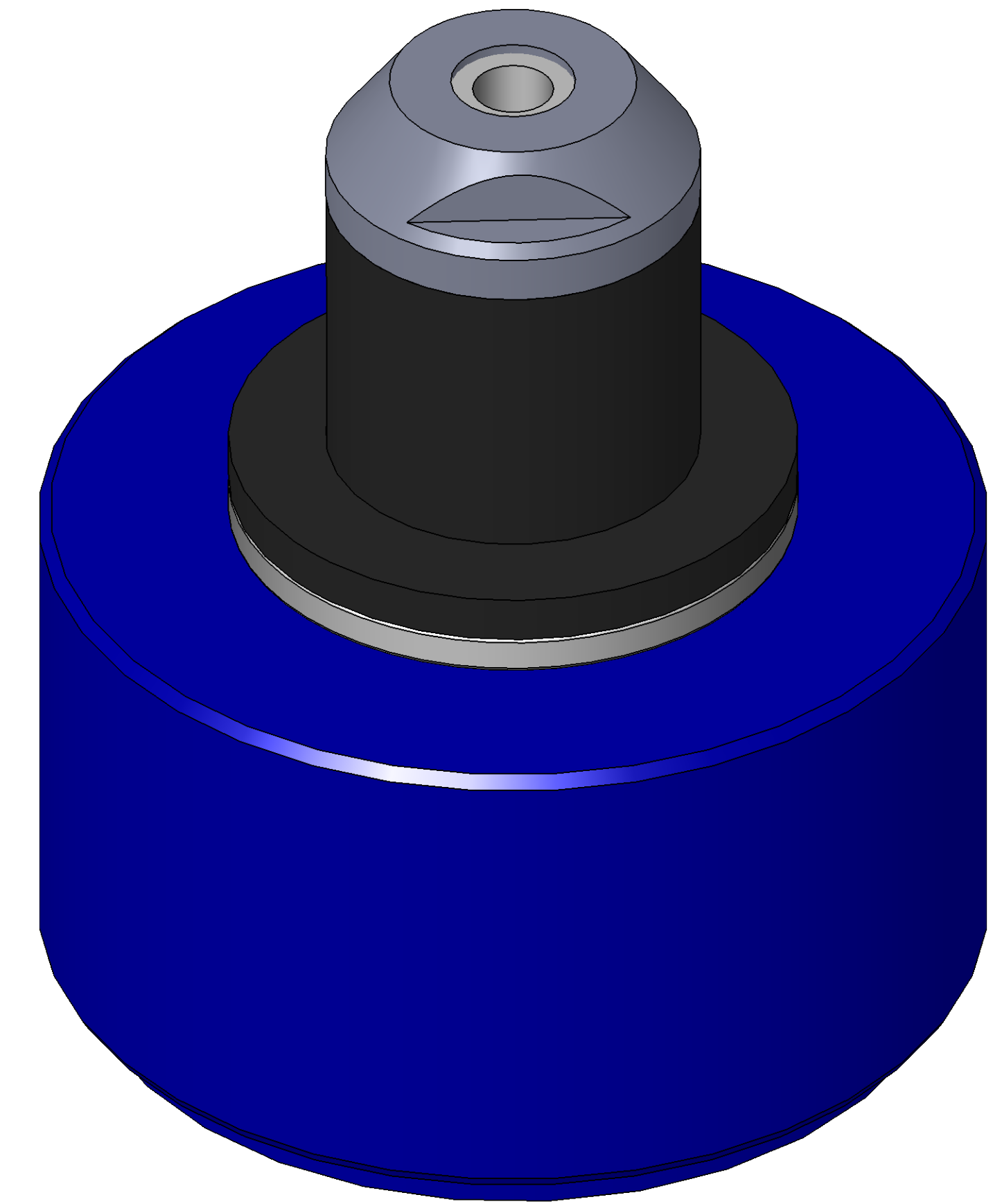

REVISIONS			
REV.	DESCRIPTION	DATE	APPROVED
A	Initial Release	07-19-2005	DAS
B	Nose material changed from brass to 316 stainless steel	12-15-2025	KM



SIZE	DESCRIPTION	REV
D	Connect Assembly, CTS, CI33-M26	B
PART NUMBER		REV
CTSC-002241		B
DATE	DRAWN BY	CHECKED BY
7/19/05		KM
SHEET		OF
1		1

FILE LOCATION: C:\PDM\PDM\R&D Product Development\CTS Connects\CI\Connect Assembly\CI33\CTSC-002241

Monday, December 15, 2025