

SECTION A-A

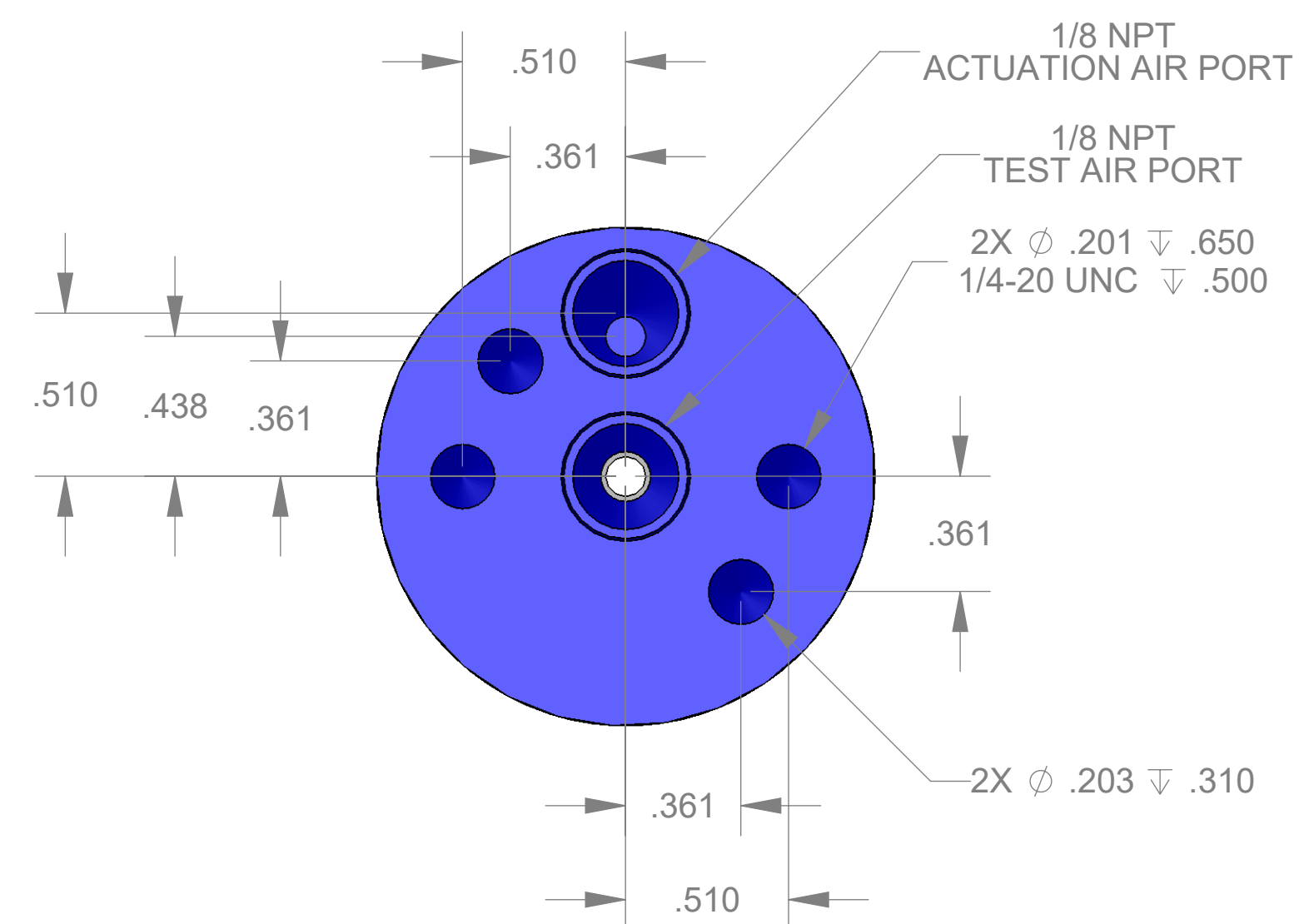

| ITEM NO. | PART NUMBER | DESCRIPTION                 | QTY. |
|----------|-------------|-----------------------------|------|
| 10       | MACH-004182 | Body, CTS, CI32             | 1    |
| 20       | MACH-004249 | Cap, CTS, CI32              | 1    |
| 30       | MACH-054208 | Stem, CTS, CI32-E2.0        | 1    |
| 40       | SEAL-005436 | CI31-ORING 109              | 1    |
| 50       | SEAL-005438 | CI31-ORING 216              | 1    |
| 60       | MACH-004312 | Nose, CTS, CI32-MET-G       | 1    |
| 70       | SEAL-004836 | Seal, CTS, CI32-MET-G       | 1    |
| 80       | MACH-004440 | Washer, CTS, CI32-MET-G     | 1    |
| 90       | MACH-004580 | Spacer Extension, CTS, CI32 | 2    |

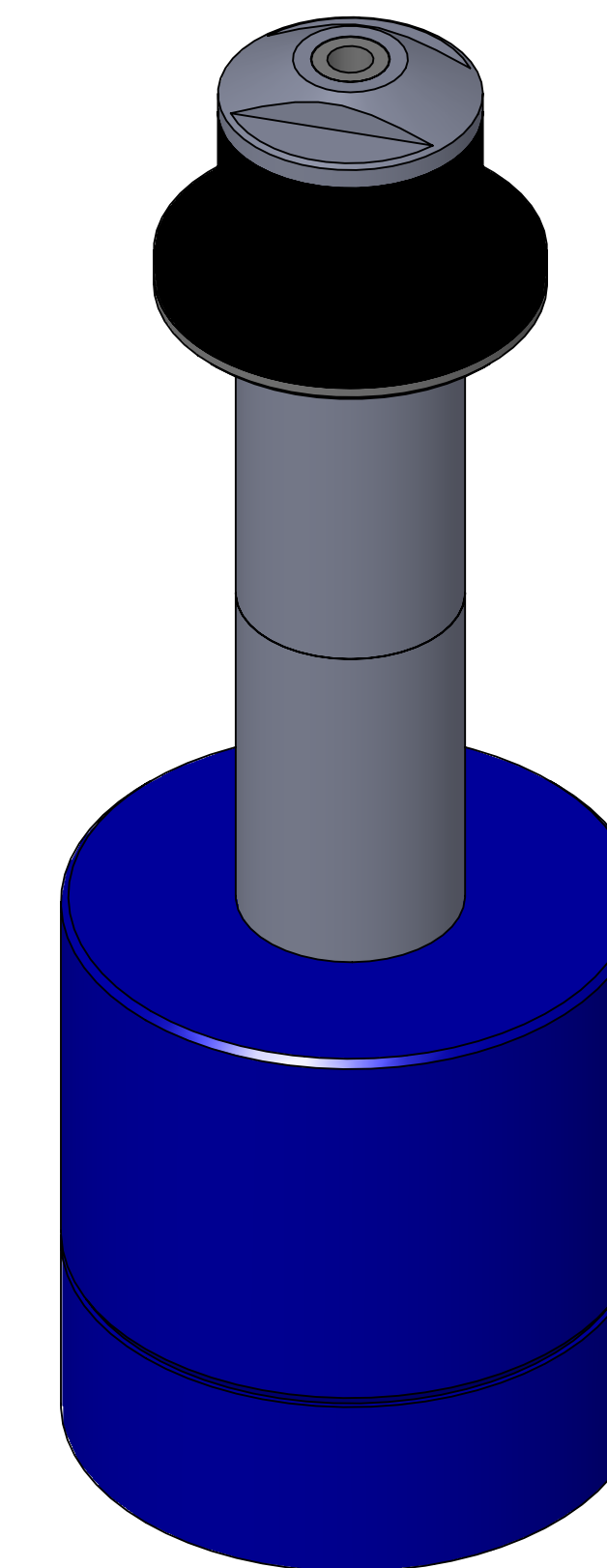

| REVISIONS |   |            |          |
|-----------|---|------------|----------|
| REV.      | DESCRIPTION   | DATE       | APPROVED |
| A         | Initial Release   | 03-31-2026 | KM       |
| B         | Nose material changed from brass to 316 stainless steel | 04-06-2026 | KM       |



10100 PROGRESS WAY HARRISON, OH 45030

|             |                                      |            |
|-------------|--------------------------------------|------------|
| SIZE        | DESCRIPTION                          | REV        |
| D           | Connect Assembly, CTS, CI32-M20-E2.0 | B          |
| PART NUMBER |                                      | REV        |
| CTSC-002201 |                                      | B          |
| DATE        | DRAWN BY                             | CHECKED BY |
| 5/13/05     | KM                                   | KM         |
| SHEET       |                                      | OF         |
| 1           |                                      | 1          |

FILE LOCATION: \\PDM\PDM\R&D\Product Development\CTS Connects\CI\Connect Assembly\Standard\CI32\2in Stem Extension\CTSC-002201