

ITEM NO.	PART NUMBER	DESCRIPTION	QTY.
10	MACH-004181	BODY, CTS, CI31	1
20	MACH-004248	Cap, CTS, CI31	1
30	MACH-054204	Stem, CTS, CI31-E2.0	1
40	SEAL-005436	CI31-ORING 109	1
50	SEAL-005438	CI31-ORING 216	1
60	MACH-004299	Nose, CTS, CI31-MET-E	1
70	SEAL-004788	Seal, CTS, CI31-MET-E	1
80	MACH-004231	Washer, CTS, CI31-MET-E	1
90	MACH-004578	Spacer Extension, CTS, CI31	2

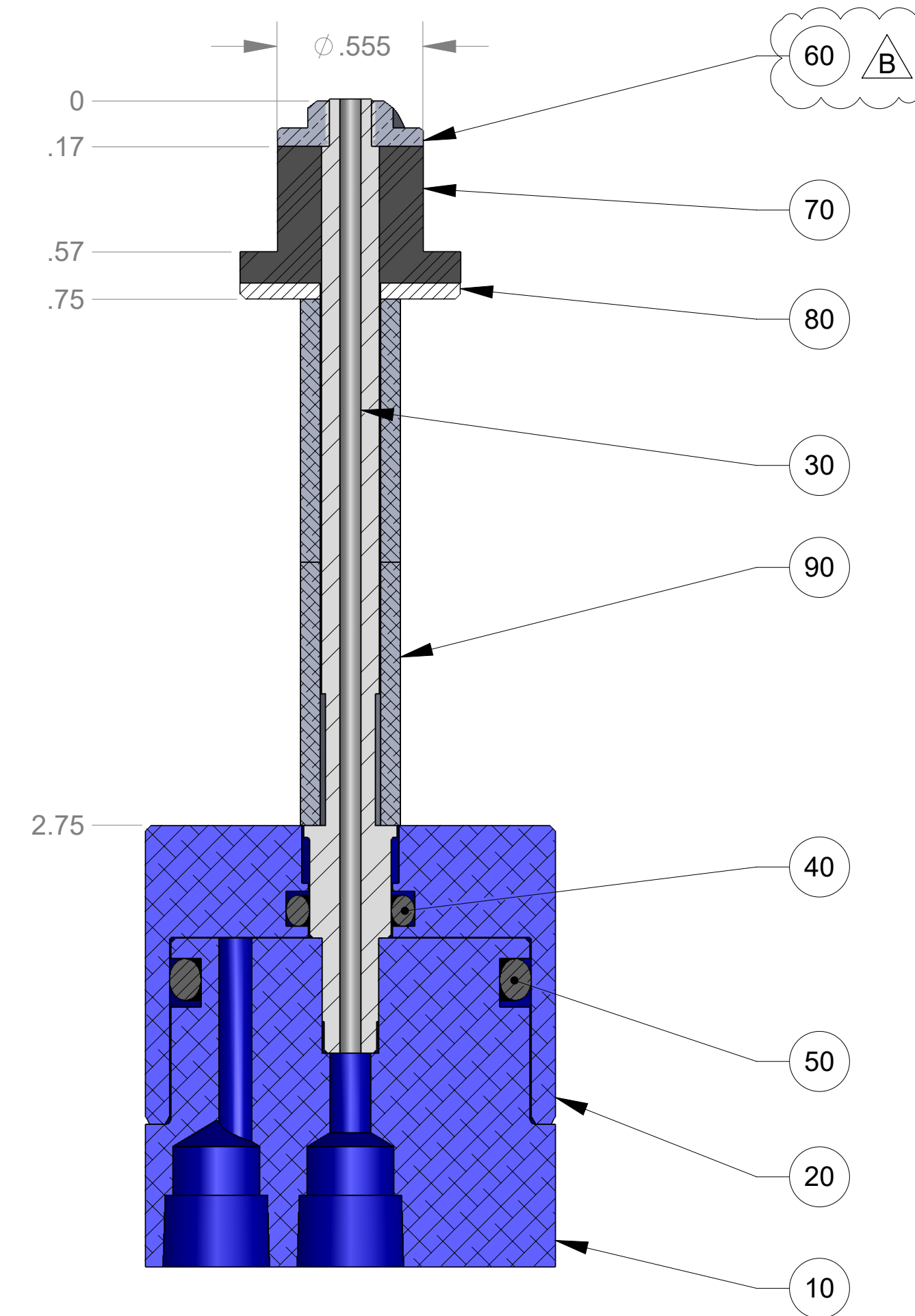

SECTION A-A

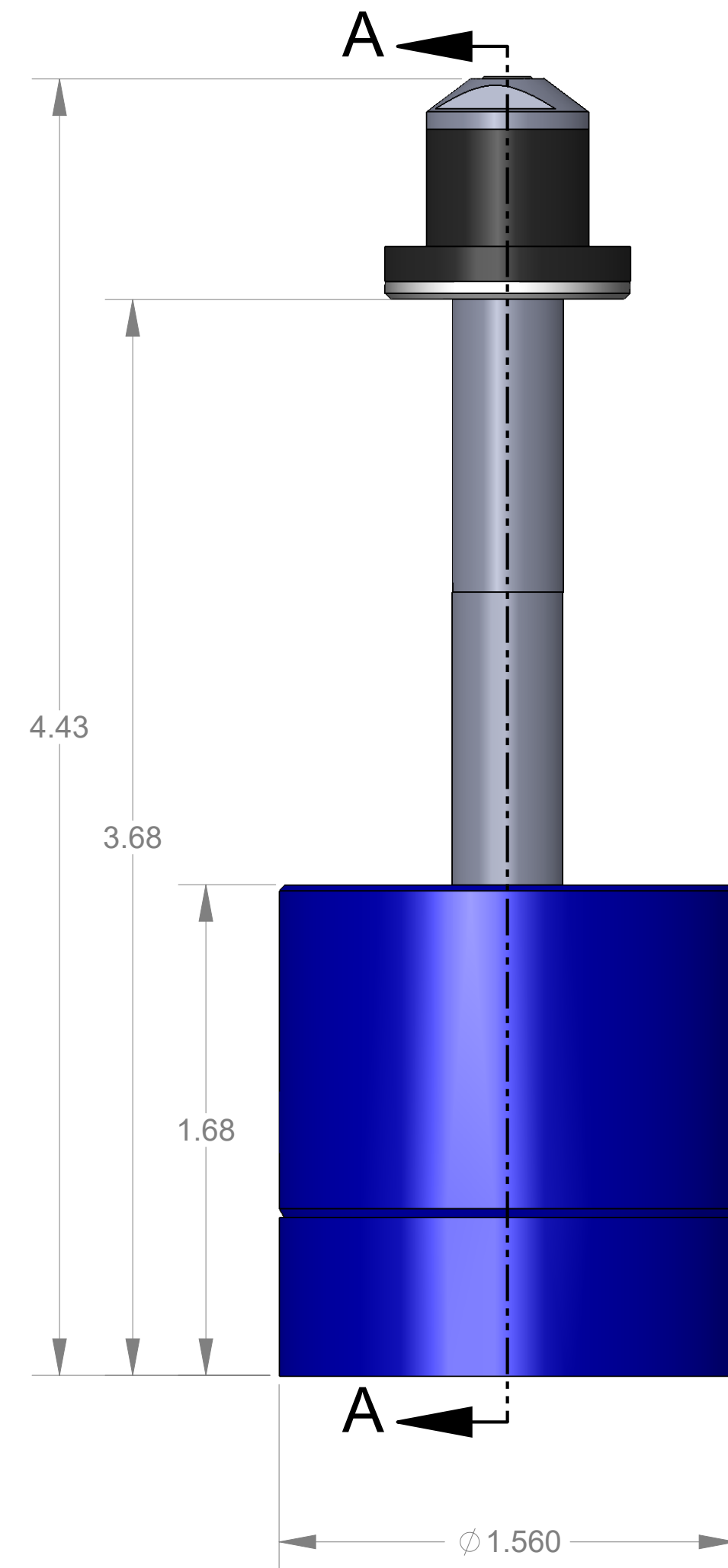
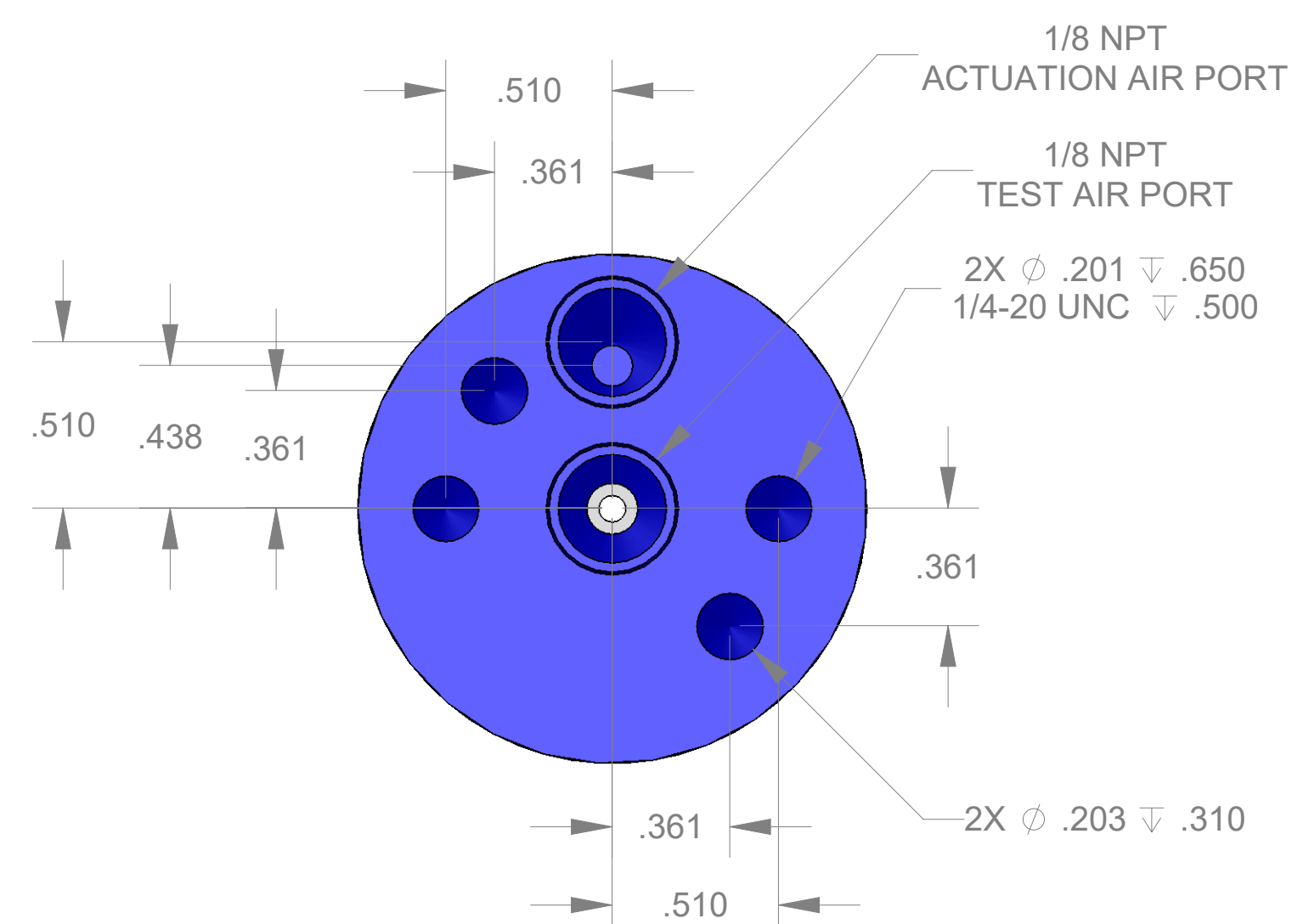
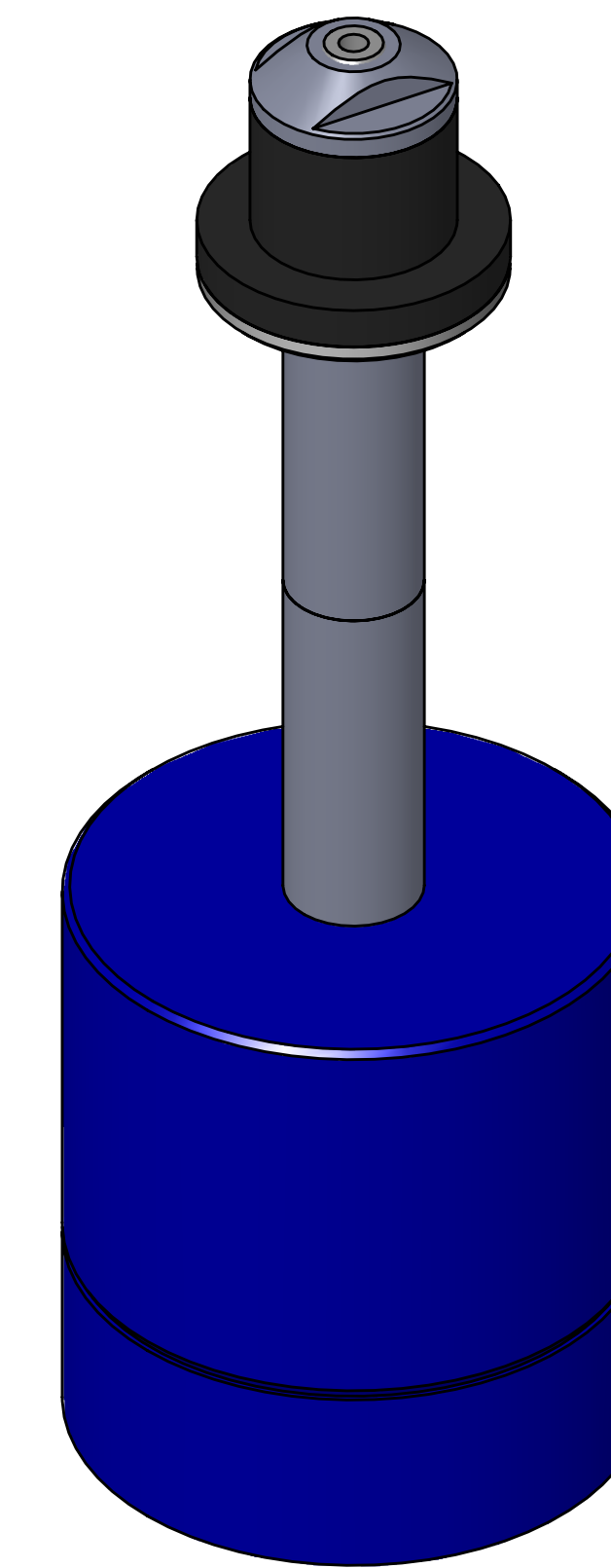

REVISIONS			
REV.	DESCRIPTION	DATE	APPROVED
A	Initial Release	02-09-2026	KM
B	Nose material changed from brass to 316 stainless steel	04-06-2026	KM



10100 PROGRESS WAY HARRISON, OH 45030

SIZE	D	DESCRIPTION	Connect Assembly, CTS, CI31-M16-E2.0
PART NUMBER	CTSC-002173		REV B
DATE	7/19/05	DRAWN BY KM	CHECKED BY KM SHEET 1 OF 1

FILE LOCATION: C:\PDM\PDM\R&D Product Development\CTS Connects\CI\Connect Assembly\Standard\CI31\2in Stem Extension\CTSC-002173