

ITEM NO.	PART NUMBER	DESCRIPTION	QTY.
10	MACH-004180	BODY, CTS, CI30	1
20	MACH-004247	Cap, CTS, CI30	1
30	MACH-004283	Nose, CTS, CI30-MET-B	1
40	MACH-004422	Washer, CTS, CI30-MET-B	1
50	MACH-054200	Stem, CTS, CI30-E2.0	1
60	SEAL-004739	Seal, CTS, CI30-MET-B	1
70	SEAL-005446	CI30-ORING 009	1
80	SEAL-005447	CI30-ORING 119	1
90	MACH-004572	Extension Spacer, CTS, CI30	2

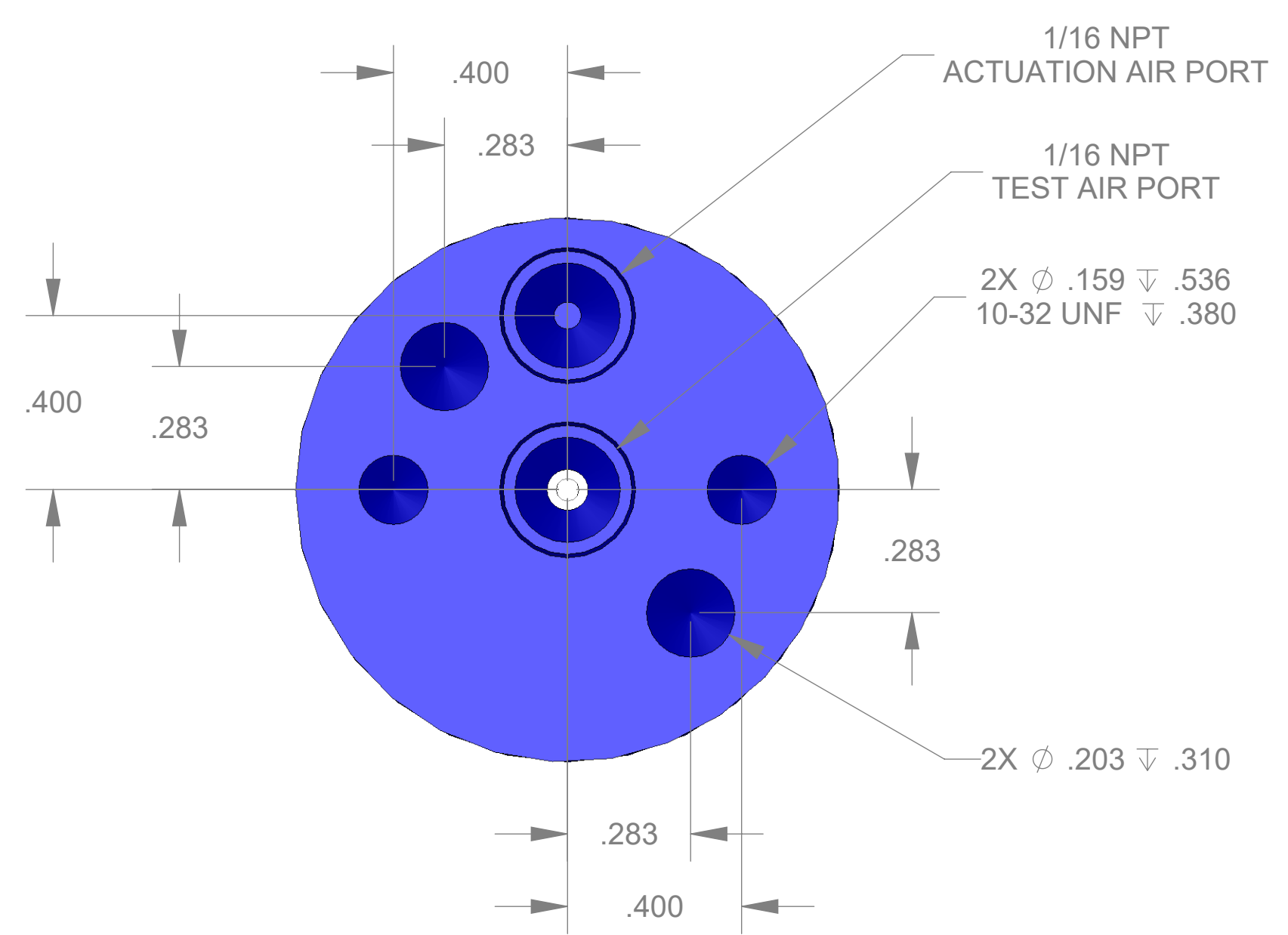

SECTION A-A
SCALE 3 : 1

REVISIONS			
REV.	DESCRIPTION	DATE	APPROVED
A	Initial Release	02-03-2026	KM
B	Nose material changed from brass to 316 stainless steel	04-06-2026	KM

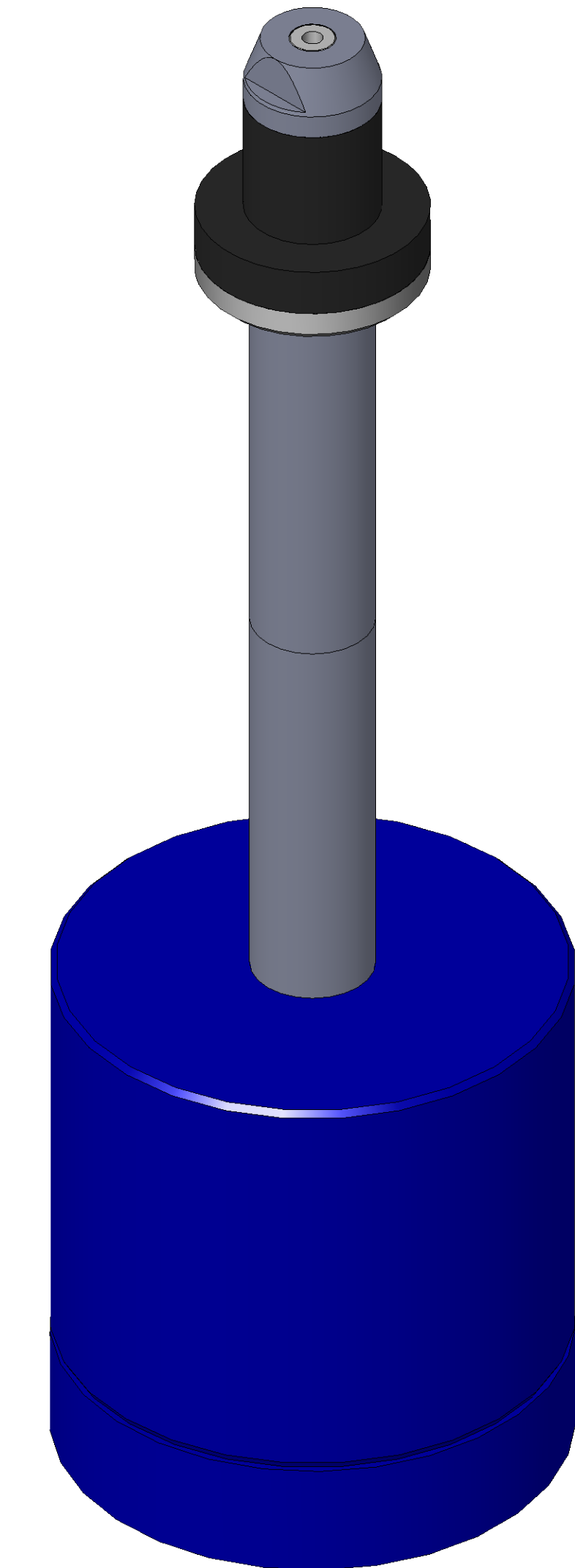

SIZE	D	DESCRIPTION	Connect Assembly, CTS, CI30-M10-E2.0
PART NUMBER	CTSC-002131		REV B
DATE	7/01/15	DRAWN BY	KM CHECKED BY KM SHEET 1 OF 1

FILE LOCATION: C:\PDM\PDM\R&D Product Development\CTS Connects\CI\Connect Assembly\Standard\CI30\2in Stem Extension\CTSC-002131

Monday, April 6, 2026