

SECTION A-A
SCALE 3 : 2

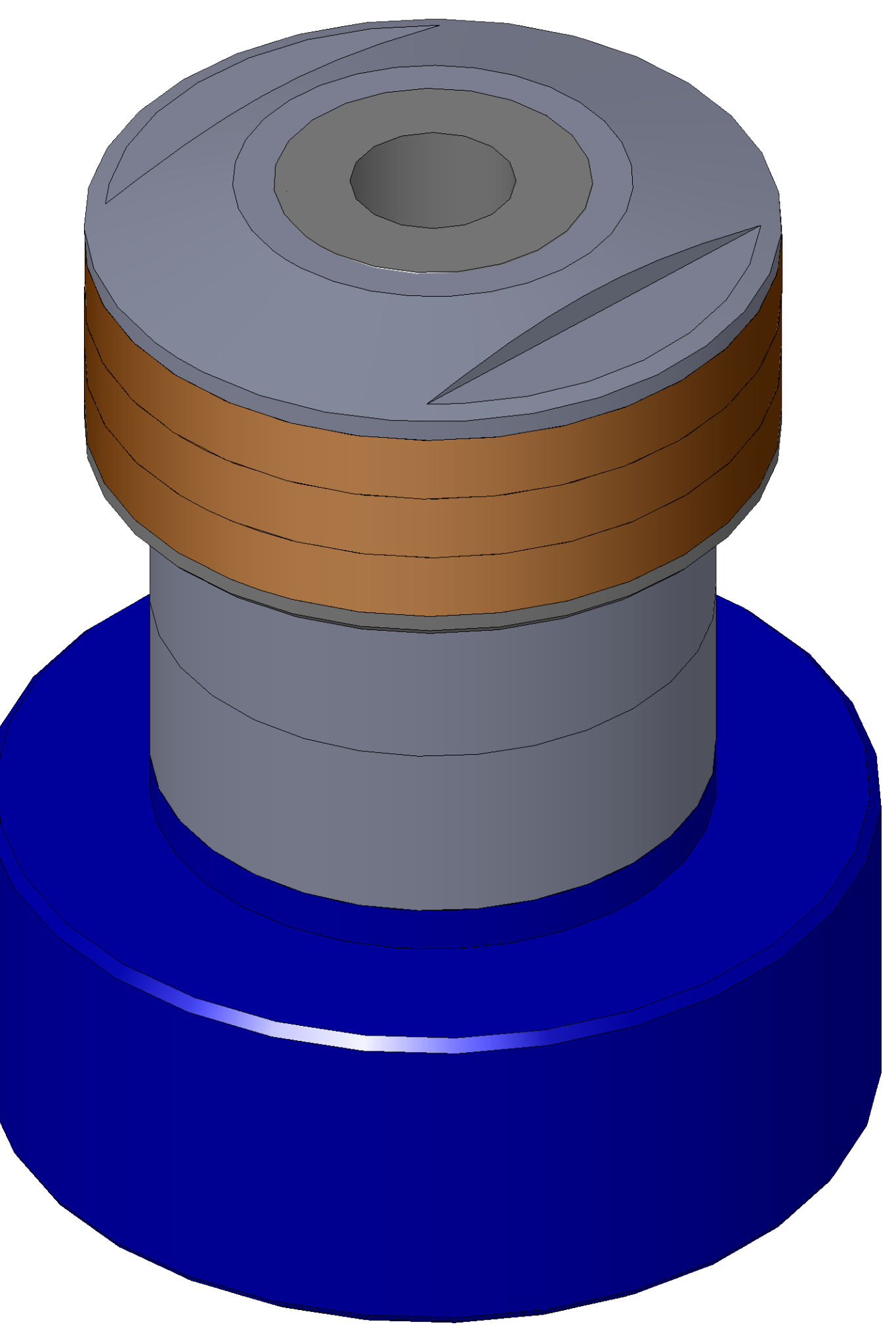

ITEM NO.	PART NUMBER	DESCRIPTION	QTY.
10	MACH-004190	Body, CTS, CI40	1
20	MACH-004257	Cap, CTS, CI40	1
30	MACH-054233	Stem, CTS, CI39/40-E2.0	1
40	MACH-004604	Spacer, CTS, CI39/40	1
50	SEAL-005442	CI39-ORING 226	1
60	SEAL-005445	CI40-ORING 346	1
70	MACH-004372	Nose, CTS, CI40-AB	1
80	SEAL-005022	Seal, CTS, CI40-AB	3
90	MACH-004488	Washer, CTS, CI40-AB	1
100	MACH-004605	Spacer Extension, CTS, CI39-CI40	2

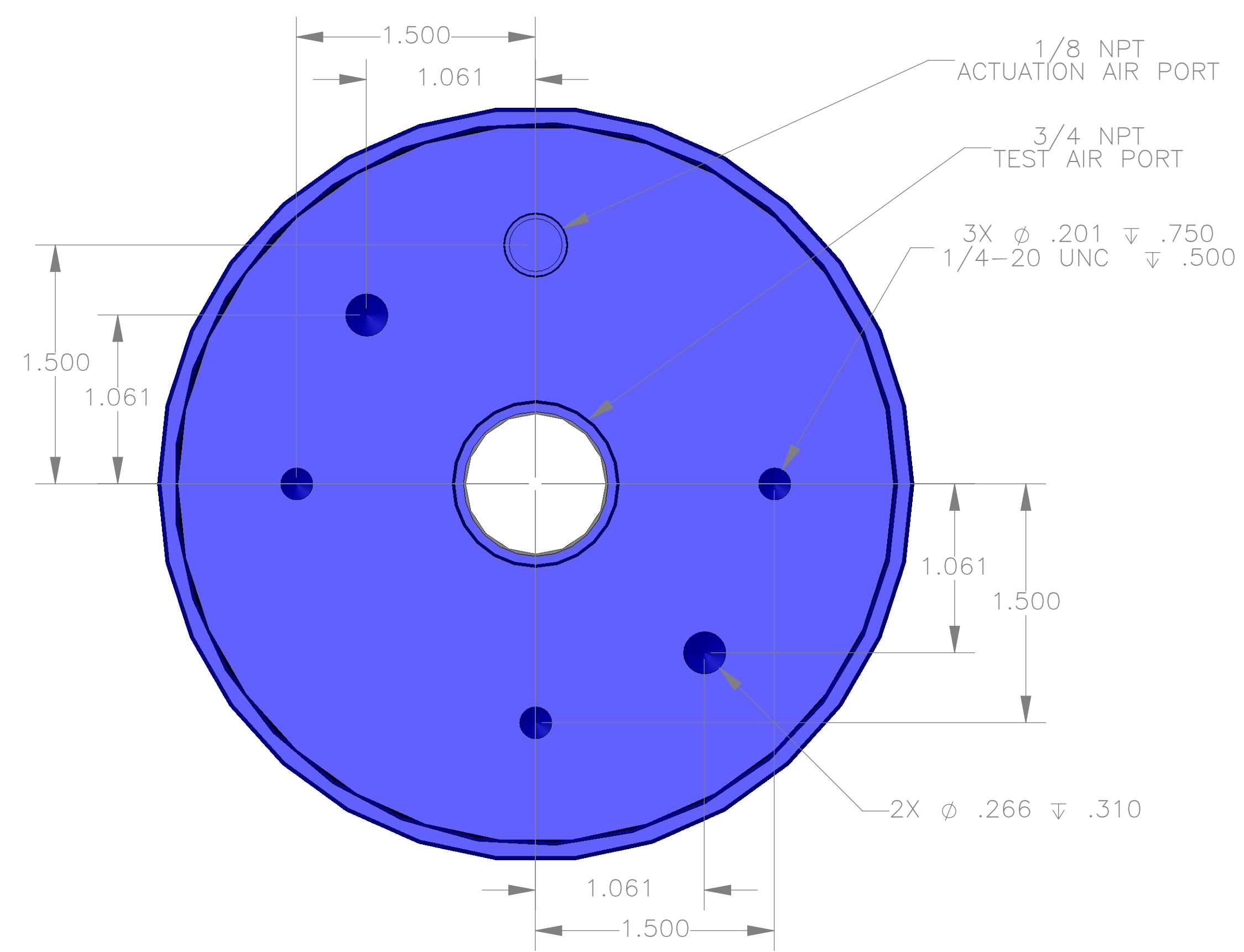

REVISIONS			
REV.	DESCRIPTION	DATE	APPROVED
A	Initial Release	03-11-2026	KM
B	Nose material changed from brass to 316 stainless steel	03-12-2026	KM



SIZE	DESCRIPTION	REV
D	Connect Assembly, CTS, CI40-AB-E2.0	B
PART NUMBER		REV
CTSC-002075		B
DATE	DRAWN BY	CHECKED BY
8/12/05	KM	KM
SHEET		OF
1		1

FILE LOCATION: C:\PDM\PDM\R&D Product Development\CTS Connects\CI\Connect Assembly\Standard\CI40\2in Stem Extension\CTSC-002075

Thursday, March 12, 2026