

SECTION A-A
SCALE 3 : 2

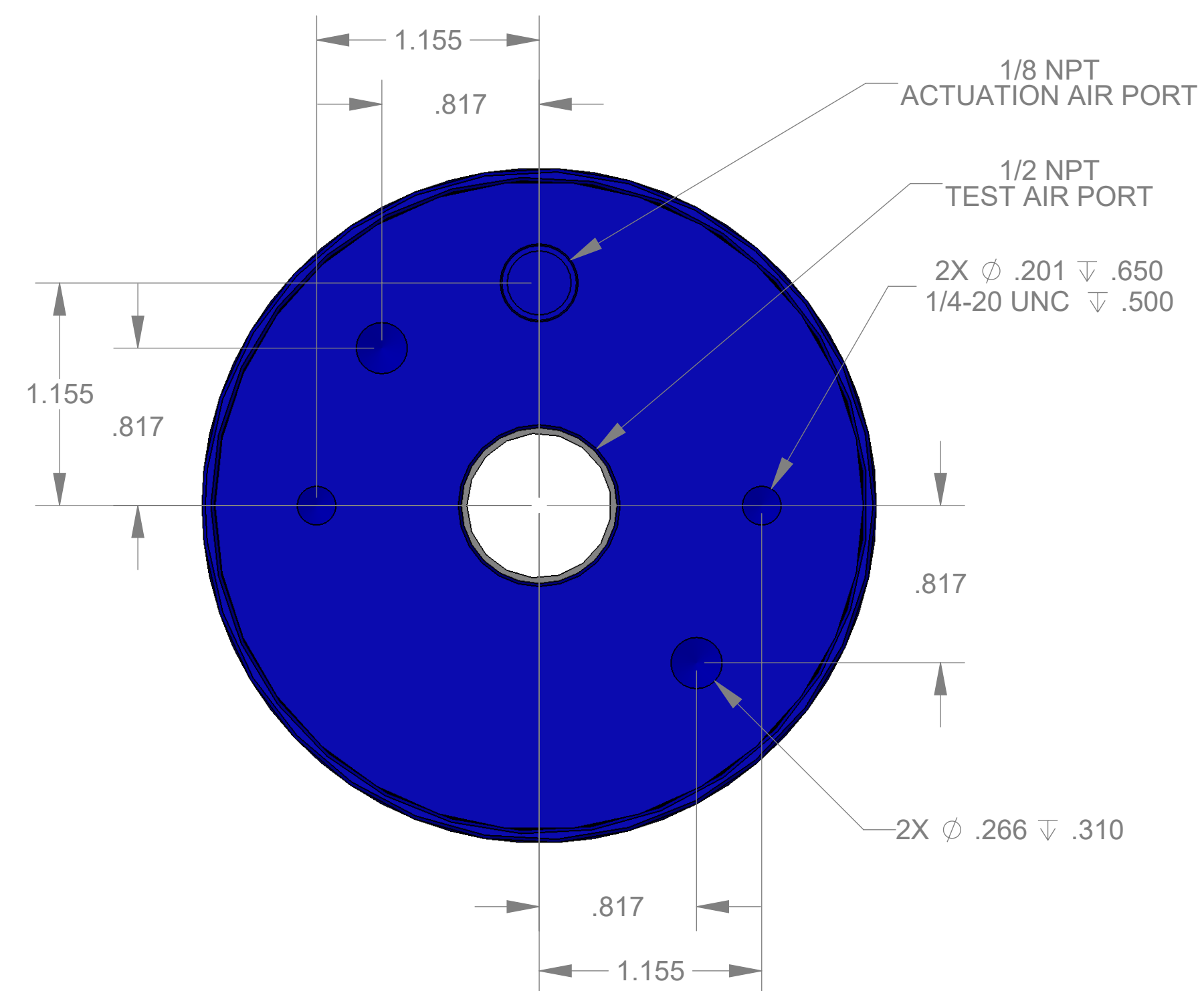

ITEM NO.	PART NUMBER	DESCRIPTION	QTY.
10	MACH-004186	Body, CTS, CI36	1
20	MACH-004253	Cap, CTS, CI36	1
30	MACH-054226	Stem, CTS, CI36-E3.0	1
40	MACH-004597	Spacer, CTS, CI36	1
50	SEAL-005439	CI36-ORING 217	1
60	SEAL-005443	CI35-ORING 337	1
70	MACH-004350	Nose, CTS, CI36-AC	1
80	SEAL-004953	Seal, CTS, CI36-AC-M	3
90	MACH-004466	Washer, CTS, CI36-AC	1
100	CI36-S-1.00	Spacer Extension, CTS, CI36	3

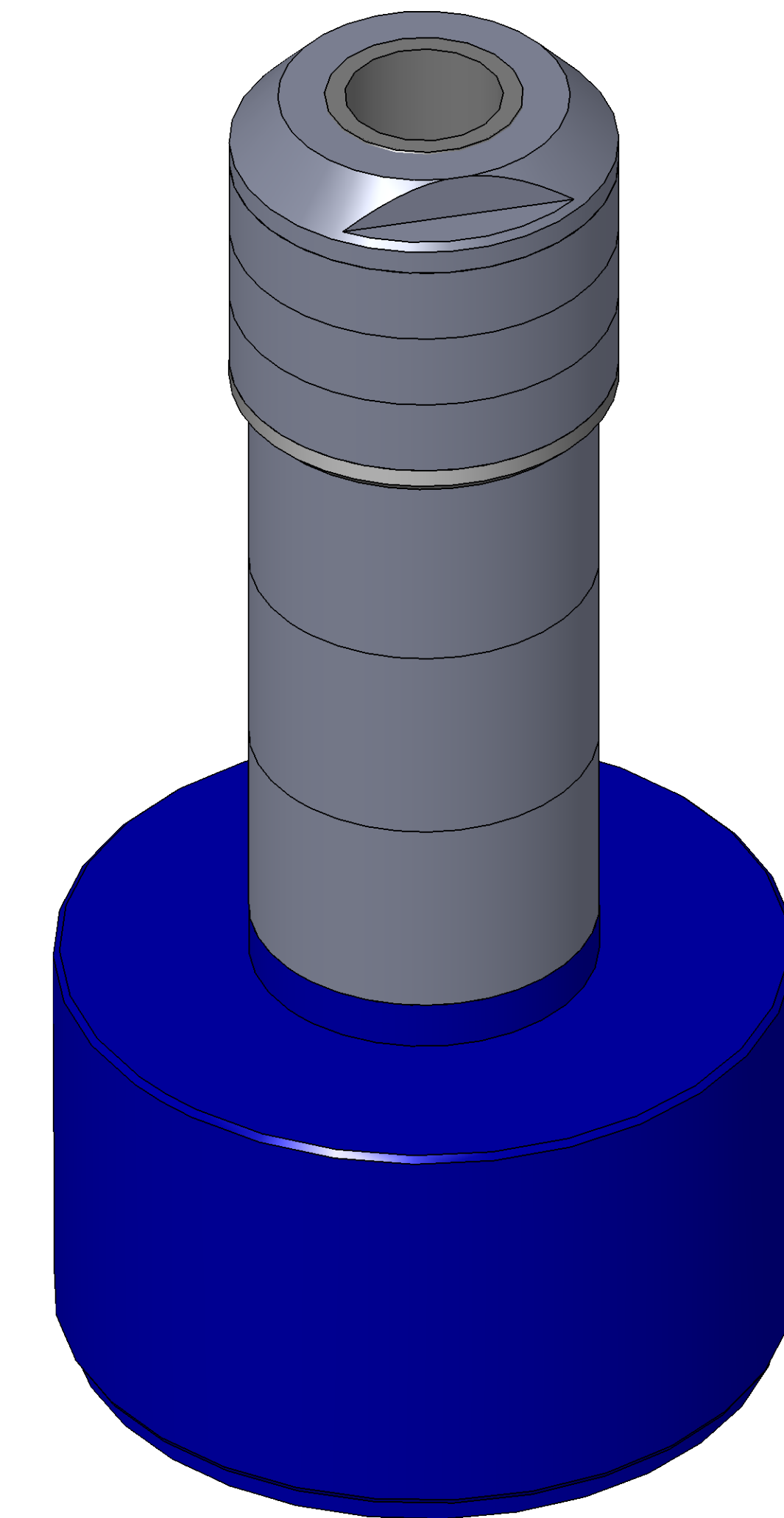

REVISIONS			
REV.	DESCRIPTION	DATE	APPROVED
A	Initial Release	03-16-2026	KM
B	Changed material of nose and seal	03-17-2026	KM



SIZE	DESCRIPTION	REV
D	Connect Assembly, CTS, CI36-AC-E3.0-M	B
PART NUMBER	CTSC-001865	
DATE	DRAWN BY: KM	CHECKED BY: KM
SHEET 1 OF 1		

FILE LOCATION: C:\PDM\PDM\R&D\Product Development\CTS Connects\CI\Connect Assembly\Medical\CI36-M\3in Stem Extension\CTSC-001865