

SECTION A-A
SCALE 3 : 2

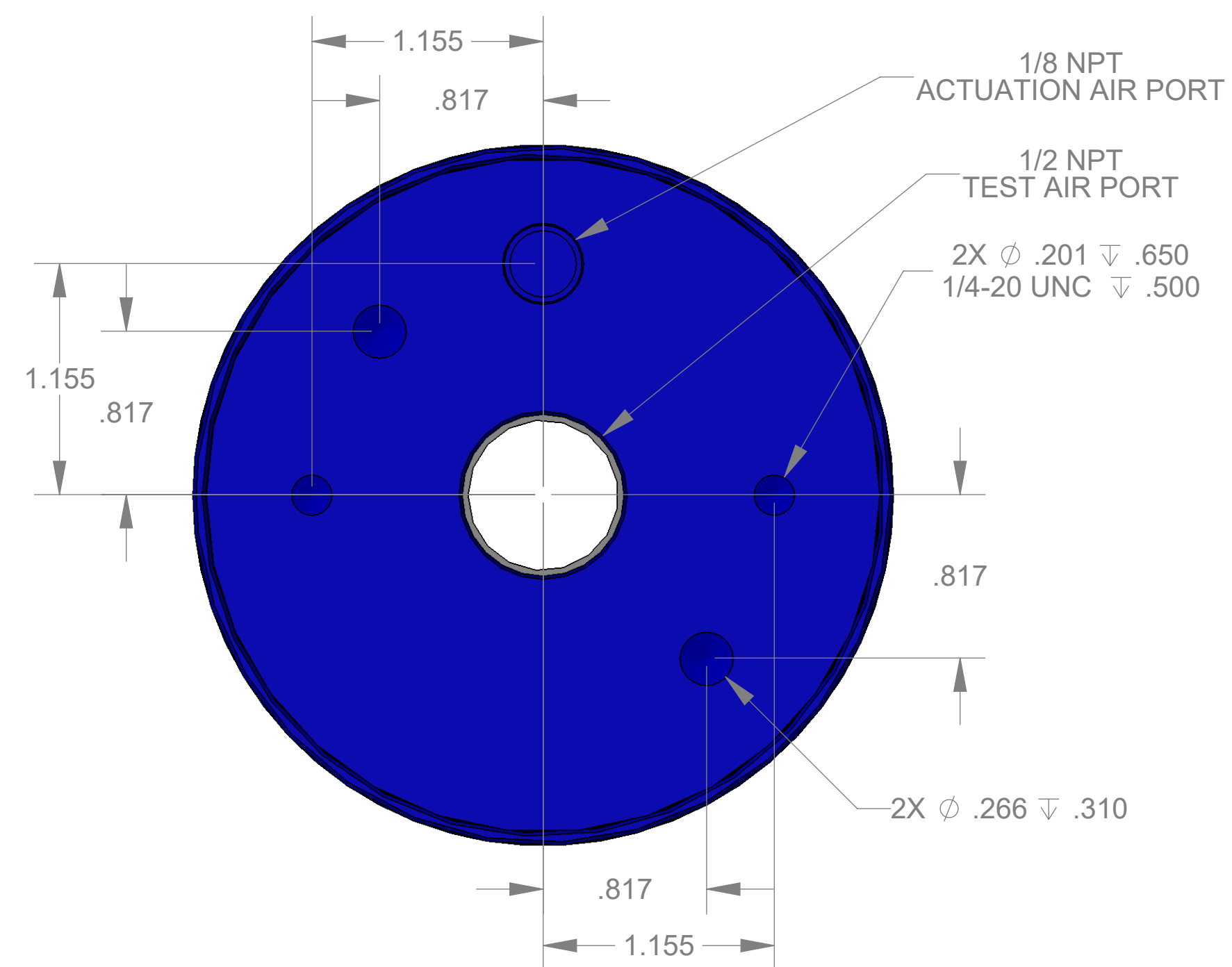

ITEM NO.	PART NUMBER	DESCRIPTION	QTY.
10	MACH-004186	Body, CTS, CI36	1
20	MACH-004253	Cap, CTS, CI36	1
30	MACH-054226	Stem, CTS, CI36-E3.0	1
40	MACH-004597	Spacer, CTS, CI36	1
50	SEAL-005439	CI36-ORING 217	1
60	SEAL-005443	CI35-ORING 337	1
70	MACH-004350	Nose, CTS, CI36-AC	1
80	SEAL-004948	Seal, CTS, CI36-AC	3
90	MACH-004466	Washer, CTS, CI36-AC	1
100	MACH-004598	Spacer Extension, CTS, CI36	3

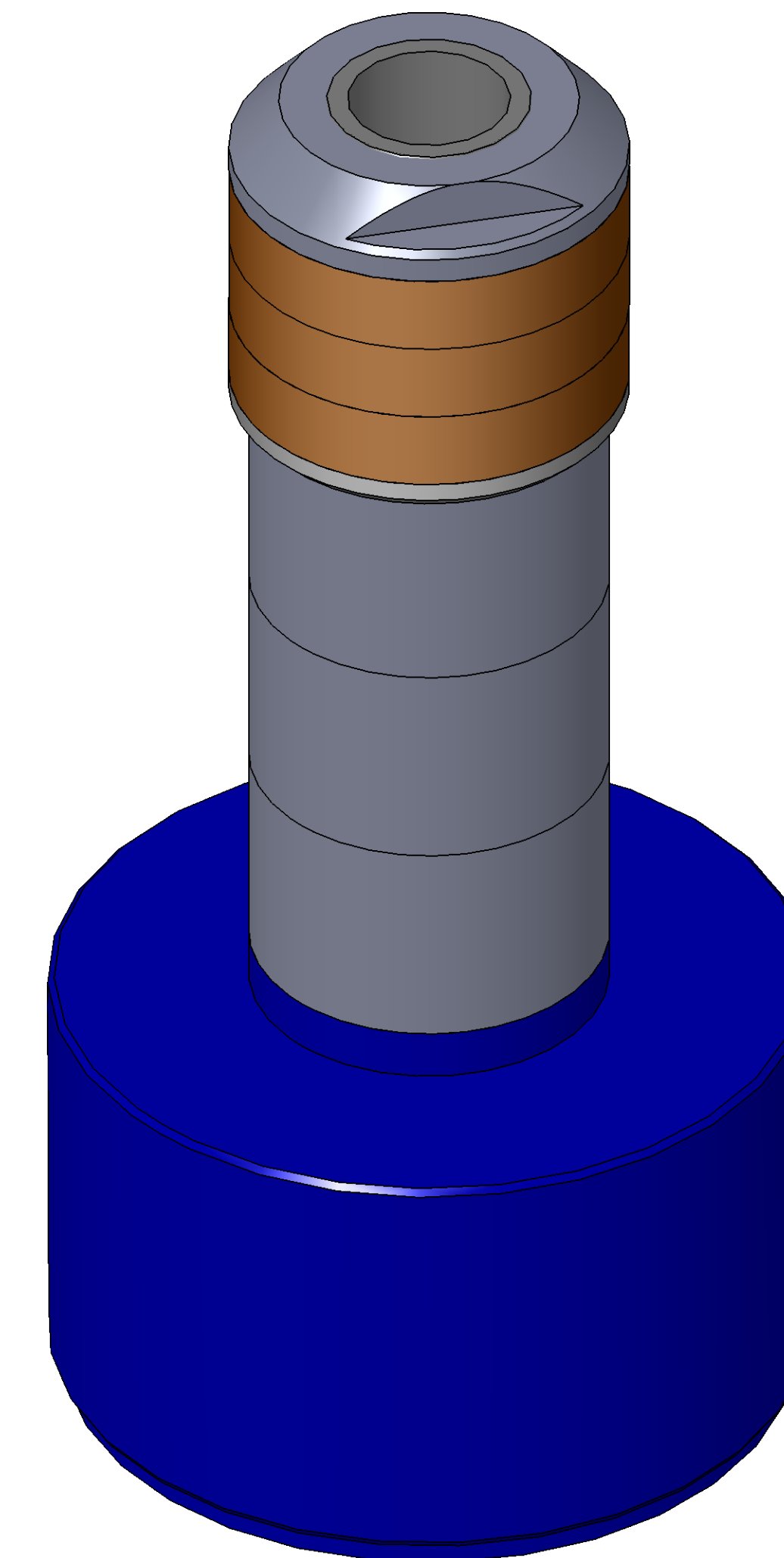

REVISIONS			
REV.	DESCRIPTION	DATE	APPROVED
A	Initial Release	03-10-2026	KM
B	Nose material changed from brass to 316 stainless steel	03-12-2026	KM



10100 PROGRESS WAY HARRISON, OH 45030

SIZE	DESCRIPTION	REV
D	Connect Assembly, CTS, CI36-AC-E3.0	B
PART NUMBER	CTSC-001860	
DATE	11/04/05	DRAWN BY: KM CHECKED BY: KM SHEET 1 OF 1