

ITEM NO.	PART NUMBER	DESCRIPTION	QTY.
10	MACH-004186	Body, CTS, CI36	1
20	MACH-004253	Cap, CTS, CI36	1
30	MACH-054224	Stem, CTS, CI36-E1.0	1
40	MACH-004597	Spacer, CTS, CI36	1
50	SEAL-005439	CI36-ORING 217	1
60	SEAL-005443	CI35-ORING 337	1
70	MACH-004348	Nose, CTS, CI36-AA	1
80	SEAL-004940	Seal, CTS, CI36-AA	3
90	MACH-004465	Washer, CTS, CI36-AA	1
100	MACH-004598	Spacer Extension, CTS, CI36	1

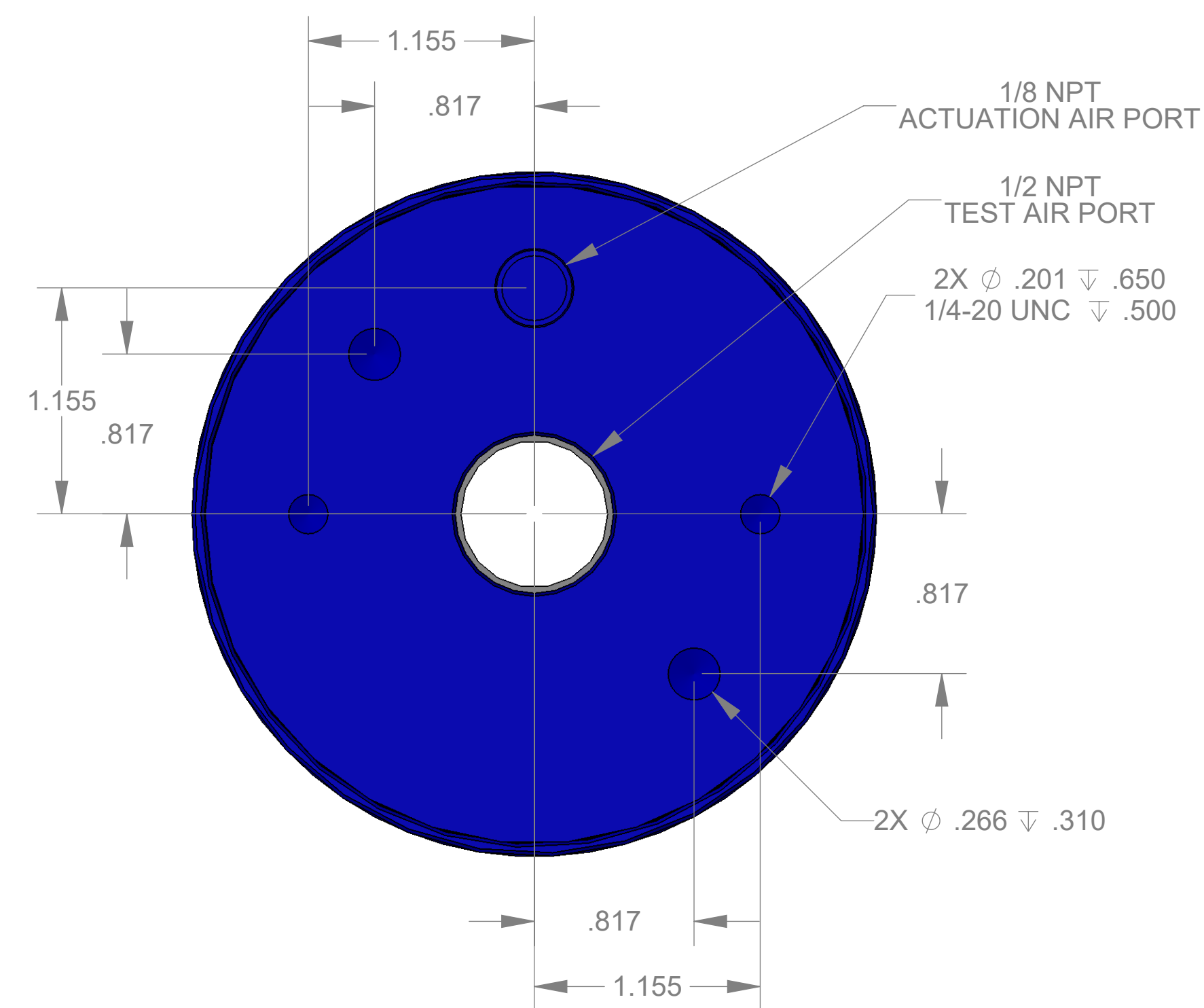

REVISIONS			
REV.	DESCRIPTION	DATE	APPROVED
A	Initial Release	01-23-2026	KM
B	Nose material changed from brass to 316 stainless steel	03-12-2026	KM

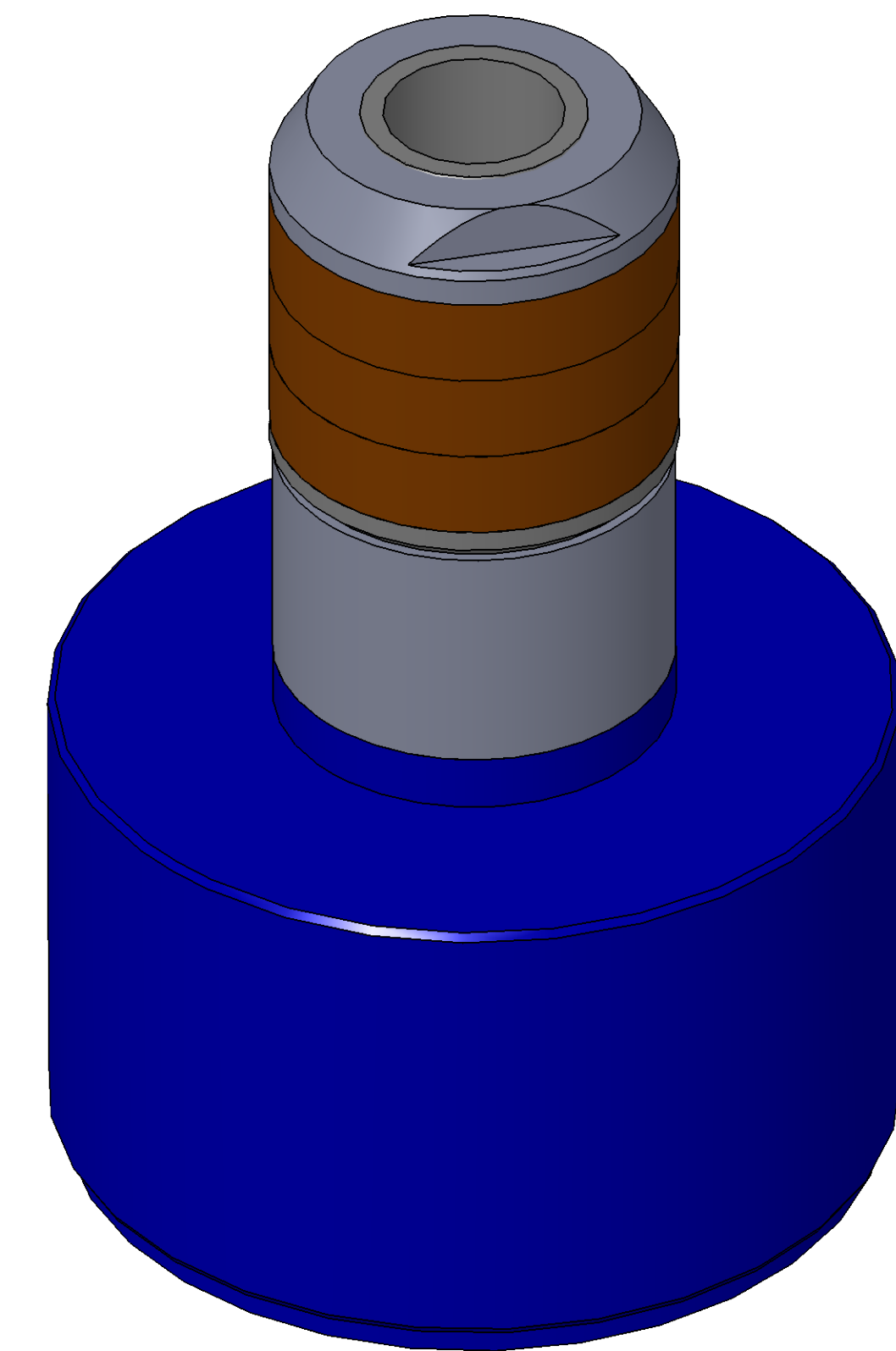

10100 PROGRESS WAY HARRISON, OH 45030

SIZE	DESCRIPTION	REV
D	Connect Assembly, CTS, CI36-AA-E1.0	B
PART NUMBER	CTSC-001830	
DATE	DRAWN BY	CHECKED BY
11/04/05	KM	KM
SHEET		1 OF 1

FILE LOCATION: C:\PDM\PDM\R&D\Product Development\CTS Connects\CI\Connect Assembly\Standard\CI36\1in Stem Extension\CTSC-001830

Monday, April 6, 2026