

ITEM NO.	PART NUMBER	DESCRIPTION	QTY.
10	MACH-004185	Body, CTS, CI35	1
20	MACH-004252	Cap, CTS, CI35	1
30	MACH-054222	Stem, CTS, CI35-E3.0	1
40	MACH-004591	Spacer, CTS, CI35	1
50	SEAL-005449	CI35-ORING 210	1
60	SEAL-005443	CI35-ORING 337	1
70	MACH-004340	Nose, CTS, CI35-AB	1
80	SEAL-004913	Seal, CTS, CI35-AB	3
90	MACH-004461	Washer, CTS, CI35-AB	1
100	MACH-004592	Spacer Extension, CTS, CI35	3

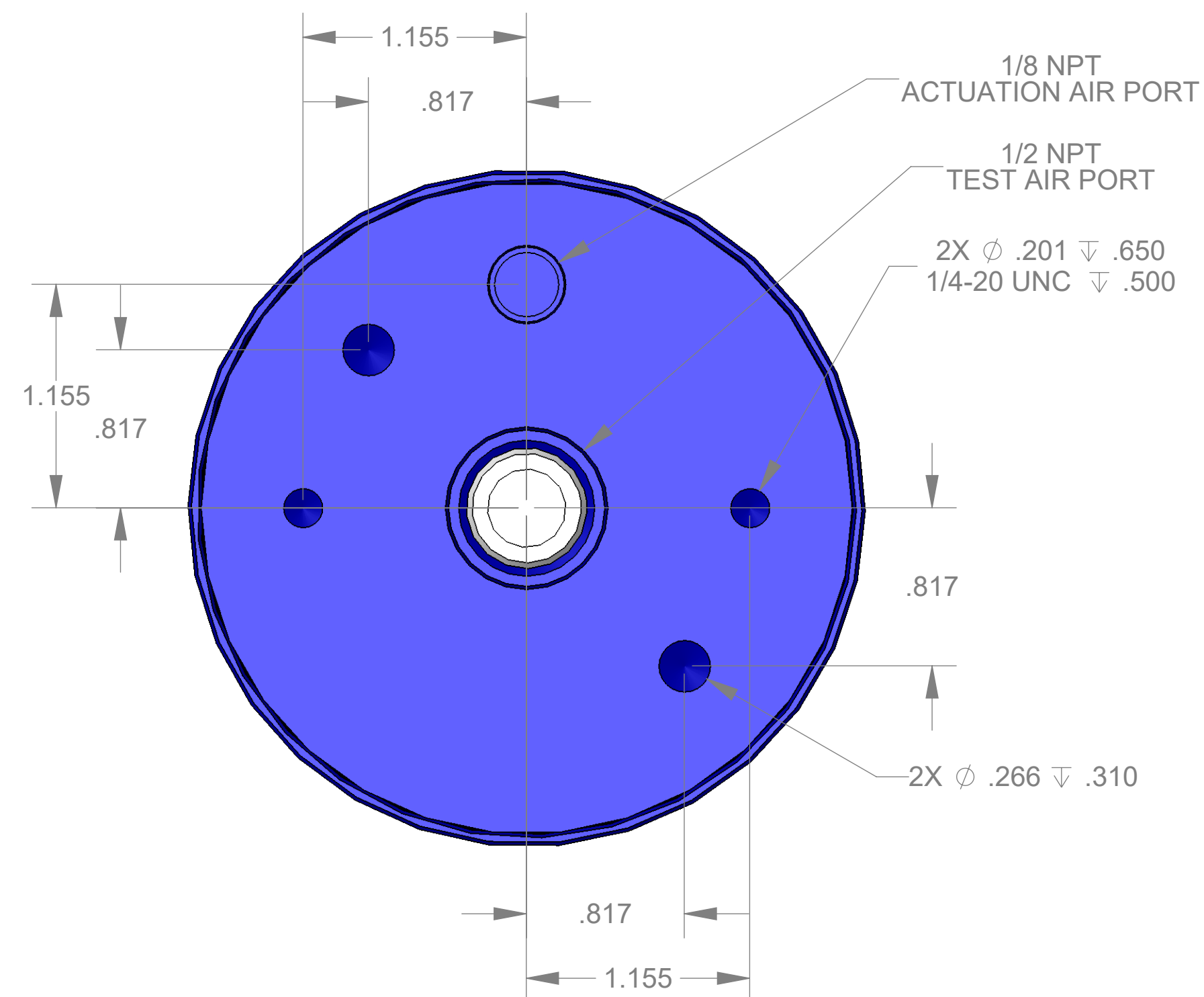

SECTION A-A  
SCALE 3:2

REVISIONS			
REV.	DESCRIPTION	DATE	APPROVED
A	Initial Release	03-10-2026	KM
B	Nose material changed from brass to 316 stainless steel	03-12-2026	KM

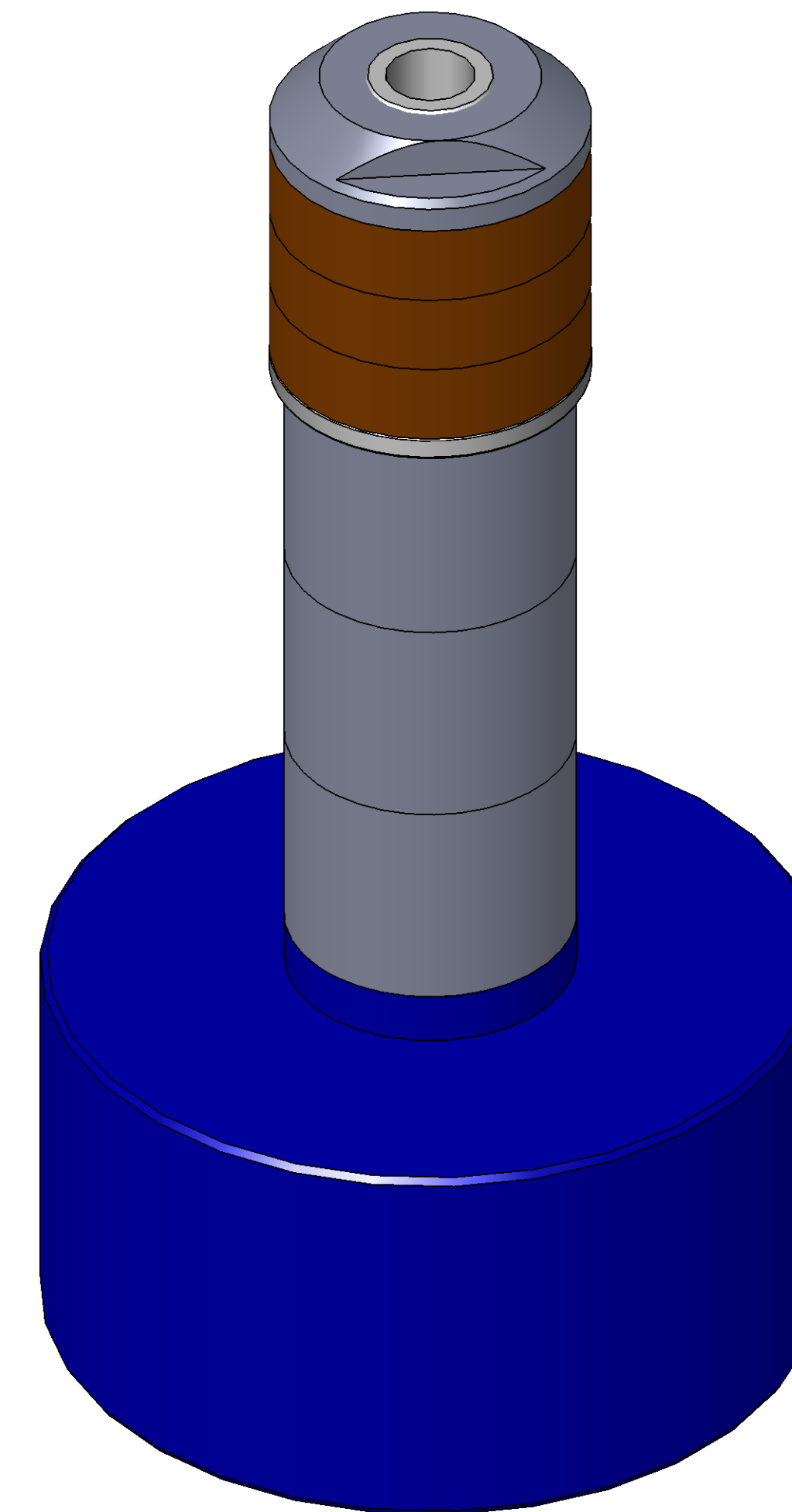

10100 PROGRESS WAY HARRISON, OH 45030

SIZE D	DESCRIPTION Connect Assembly, CTS, CI35-AB-E3.0	REV B
PART NUMBER CTSC-001785		REV B
DATE 11/04/05	DRAWN BY KM	CHECKED BY KM
SHEET 1 OF 1		