

ITEM NO.	PART NUMBER	DESCRIPTION	QTY.
10	MACH-004185	Body, CTS, CI35	1
20	MACH-004252	Cap, CTS, CI35	1
30	MACH-054219	Stem, CTS, CI35-E1.0	1
40	MACH-004591	Spacer, CTS, CI35	1
50	SEAL-005449	CI35-ORING 210	1
60	SEAL-005443	CI35-ORING 337	1
70	MACH-004338	Nose, CTS, CI35-AA	1
80	SEAL-004909	Seal, CTS, CI35-AA	3
90	MACH-004460	Washer, CTS, CI35-AA	1
100	MACH-004592	Spacer Extension, CTS, CI35	1

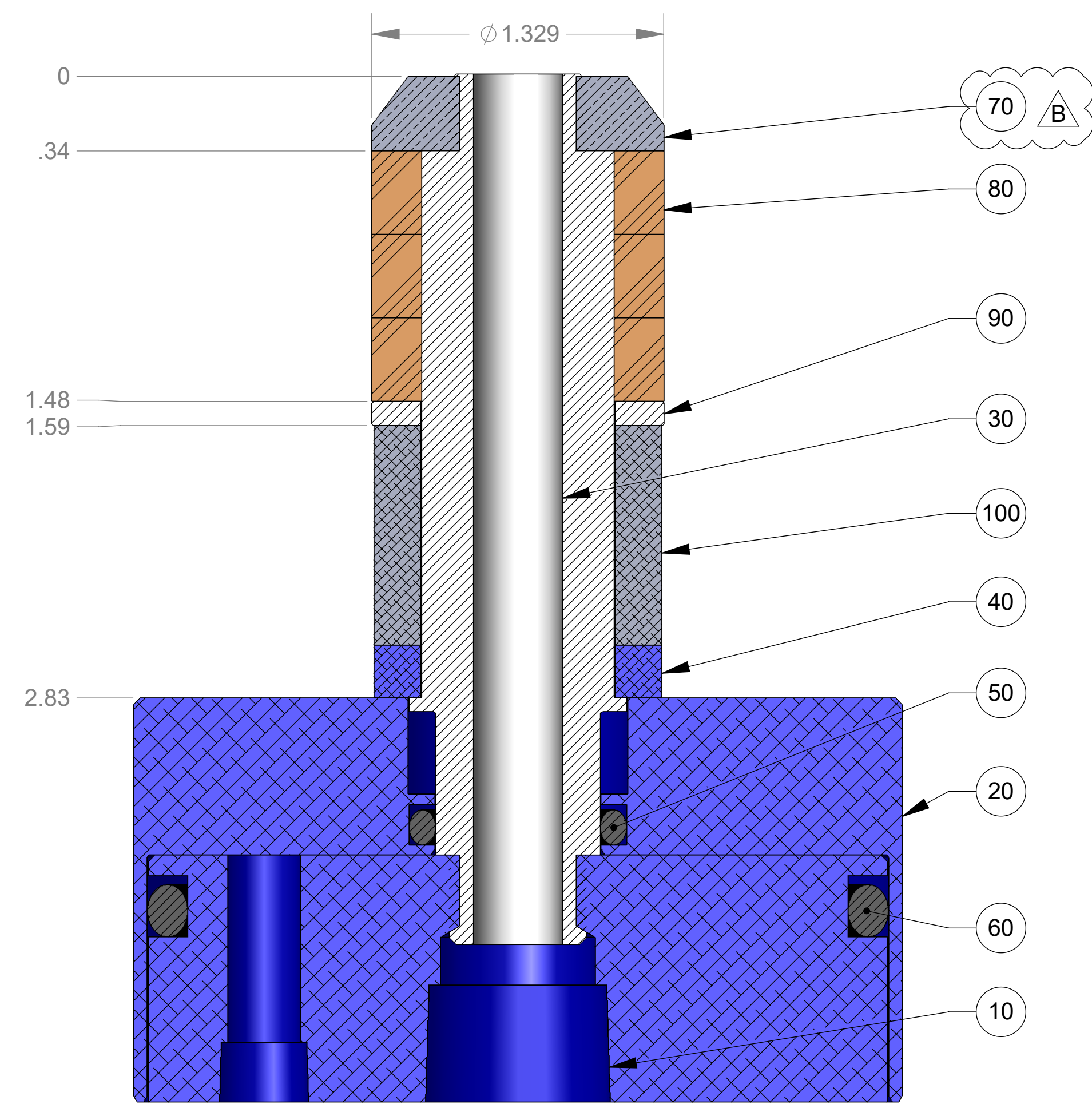

SECTION A-A
SCALE 2 : 1

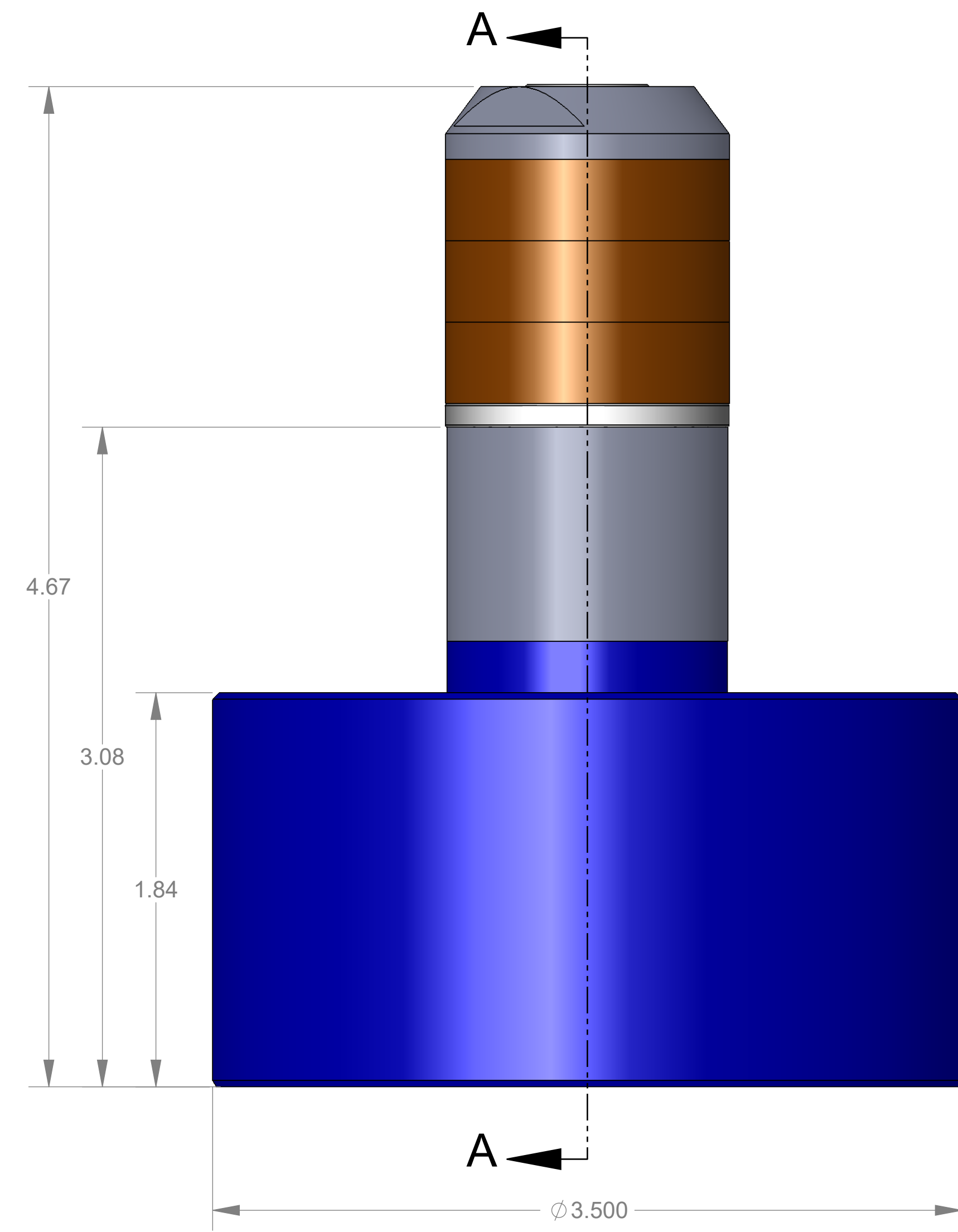
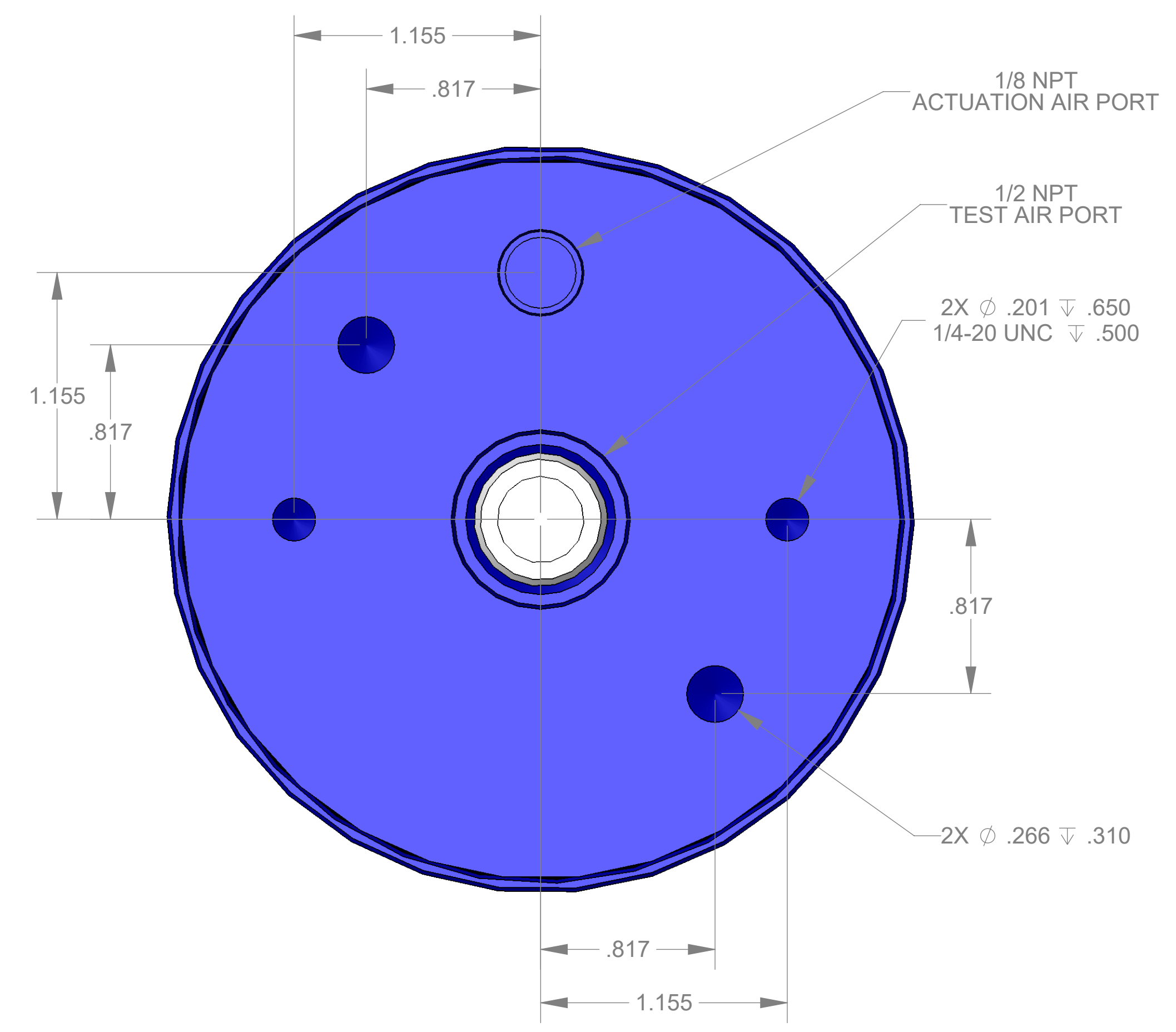
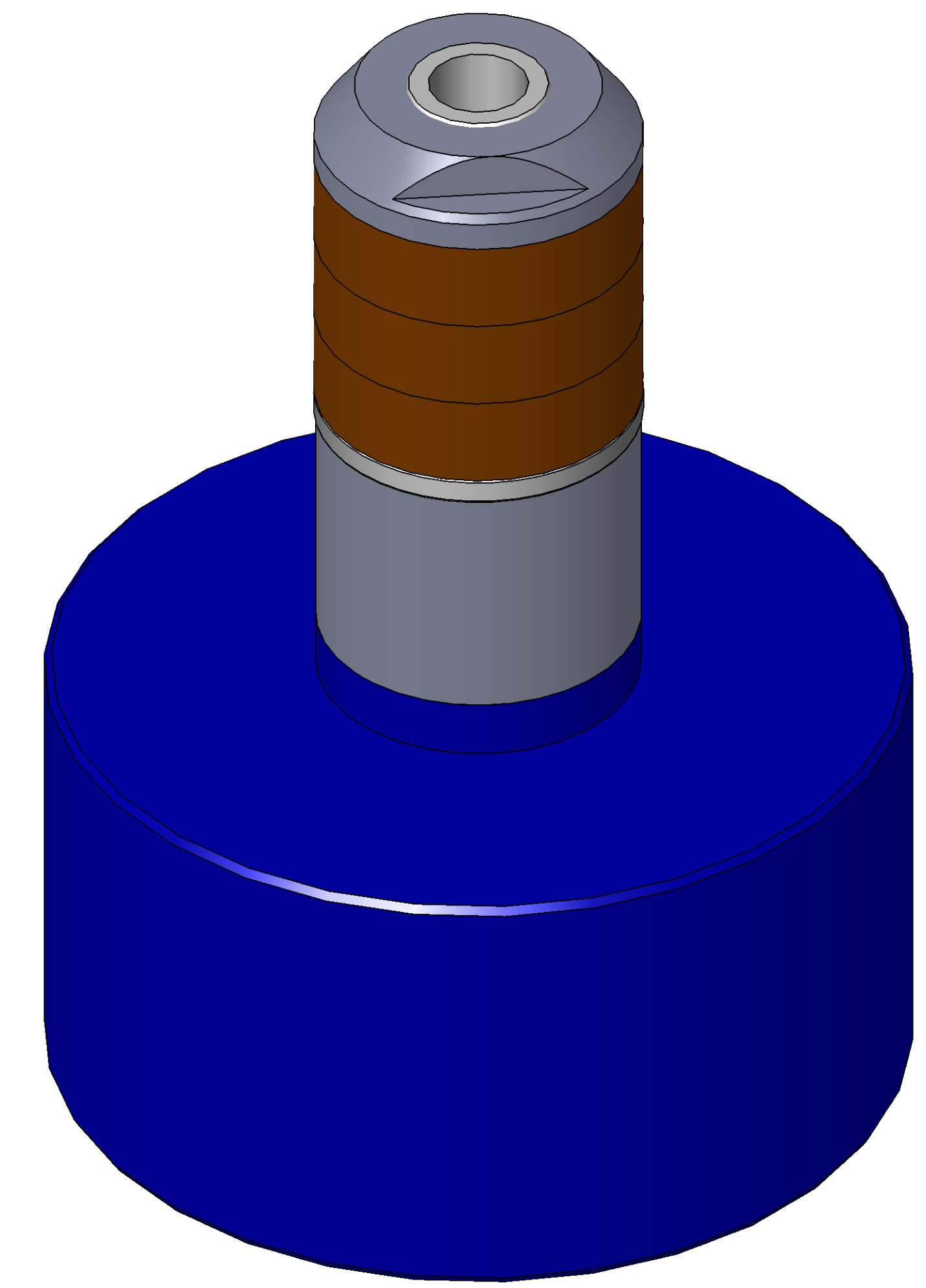

REVISIONS			
REV.	DESCRIPTION	DATE	APPROVED
A	Initial Release	01-22-2026	KM
B	Nose material changed from brass to 316 stainless steel	03-12-2026	KM



SIZE	DESCRIPTION	REV
D	Connect Assembly, CTS, CI35-AA-E1.0	B
PART NUMBER	CTSC-001769	
DATE	11/04/05	DRAWN BY: KM CHECKED BY: KM SHEET 1 OF 1

FILE LOCATION: C:\PDM\PDM\R&D Product Development\CTS Connects\CI\Connect Assembly\Standard\CI35\1in Stem Extension\CTSC-001769

Thursday, March 12, 2026