

SECTION A-A

ITEM NO.	PART NUMBER	DESCRIPTION	QTY.
10	MACH-004183	Body, CTS, CI33	1
20	MACH-004250	Cap, CTS, CI33	1
30	MACH-054213	Stem, CTS, CI33-E3.0	1
40	MACH-004585	Spacer, CTS, CI33	1
50	SEAL-005437	CI33-ORING 113	1
60	SEAL-005441	CI33-ORING 225	1
70	MACH-004319	Nose, CTS, CI33-AC	1
80	SEAL-004857	Seal, CTS, CI33-AC	2
90	MACH-004445	Washer, CTS, CI33-AC	1
100	MACH-004586	Spacer Extension, CTS, CI33	3

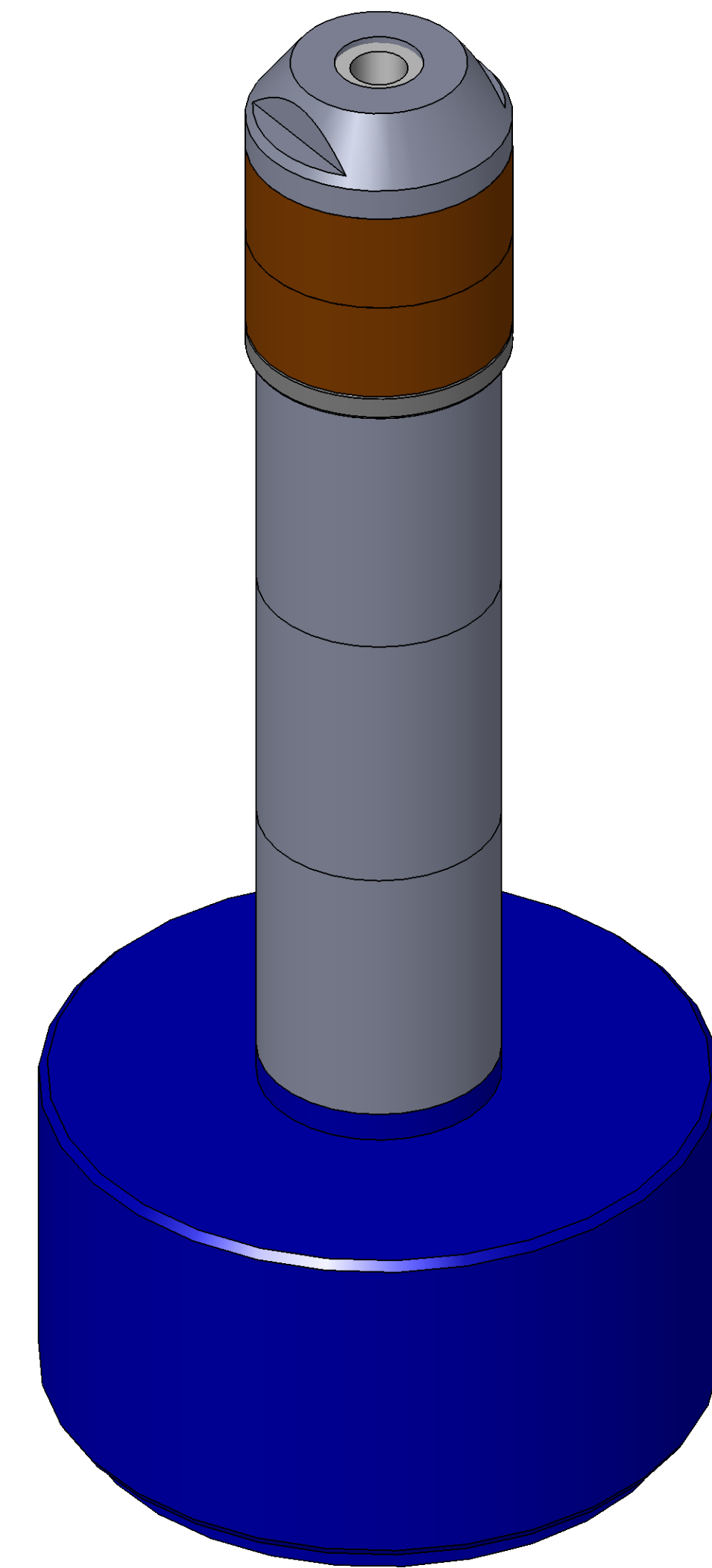

REVISIONS			
REV.	DESCRIPTION	DATE	APPROVED
A	Initial Release	03-05-2026	KM
B	Nose material changed from brass to 316 stainless steel	03-12-2026	KM



10100 PROGRESS WAY HARRISON, OH 45030

SIZE	DESCRIPTION	REV
D	Connect Assembly, CTS, CI33-AC-E3.0	B
PART NUMBER	CTSC-001677	
DATE	DRAWN BY	CHECKED BY
7/19/05	KM	KM
SHEET		1 OF 1

FILE LOCATION: C:\PDM\PDM\R&D\Product Development\CTS Connects\CI\Connect Assembly\Standard\CI33\3in Stem Extension\CTSC-001677

Thursday, March 12, 2026