

ITEM NO.	PART NUMBER	DESCRIPTION	QTY.
10	MACH-004182	Body, CTS, CI32	1
20	MACH-004249	Cap, CTS, CI32	1
30	MACH-054208	Stem, CTS, CI32-E2.0	1
40	SEAL-005436	CI31-ORING 109	1
50	SEAL-005438	CI31-ORING 216	1
60	MACH-004309	Nose, CTS, CI32-AE	1
70	SEAL-004828	Seal, CTS, CI32-AE	1
80	MACH-004438	Washer, CTS, CI32-AE	1
90	MACH-004580	Spacer Extension, CTS, CI32	2
100	MACH-004579	Spacer, CTS, CI32	1

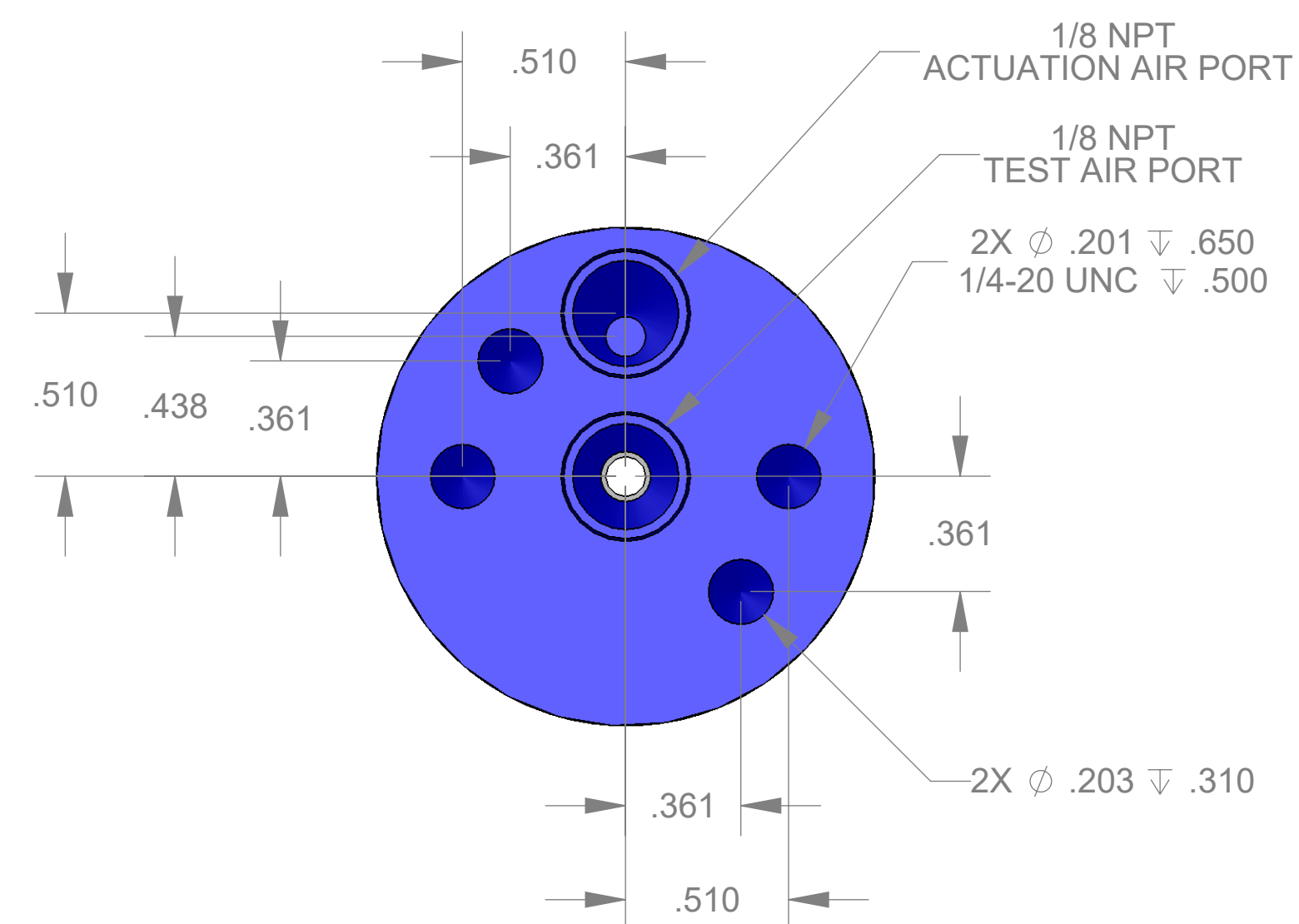

SECTION A-A

REVISIONS			
REV.	DESCRIPTION	DATE	APPROVED
A	Initial Release	03-05-2026	KM
B	Nose material changed from brass to 316 stainless steel	03-12-2026	KM

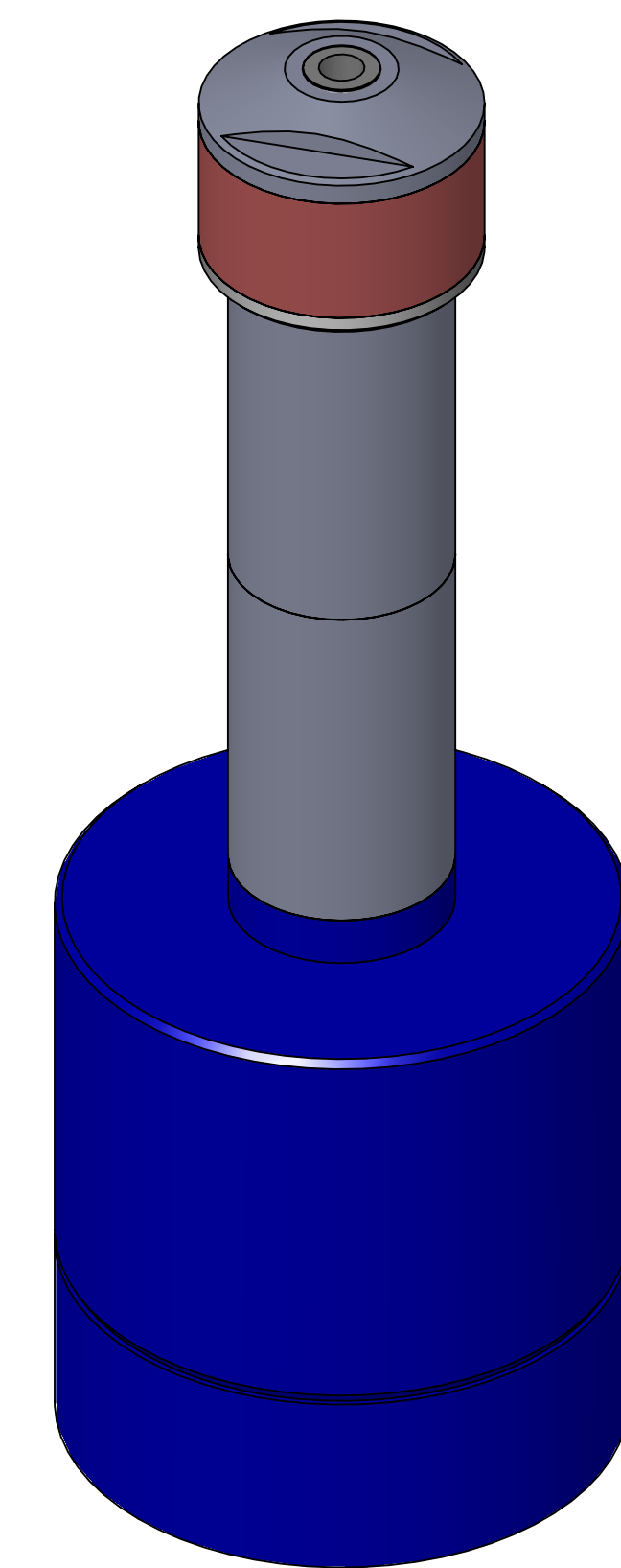

SIZE	DESCRIPTION	REV
D	Connect Assembly, CTS, CI32-AE-E2.0	B
PART NUMBER		REV
CTSC-001629		B
DATE	DRAWN BY	CHECKED BY
5/13/05	KM	KM
SHEET		OF
1		1

FILE LOCATION: \\PDM\PDM\R&D\Product Development\CTS Connects\CI\Connect Assembly\Standard\CI32\2in Stem Extension\CTSC-001629

Thursday, March 12, 2026