

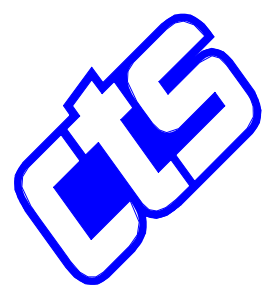

DESCRIPTION: SEAL		UNLESS OTHERWISE SPECIFIED BREAK ALL SHARP CORNERS			 5555 DRY FORK RD. CLEVELAND, OH 45002	
MATERIAL: URETHANE		TOLERANCES: 1 PLACE DECIMAL $\pm .060"$ 2 PLACE DECIMAL $\pm .020"$ 3 PLACE DECIMAL $\pm .005"$ ANGULAR DIMS $\pm 0^\circ 30'$			CUSTOMER: CTS	
FINISH: N/A		✓ INDICATES 500 MAXIMUM FINISH REQ'D ON SURFACES WITHOUT A SYMBOL		TITLE: SEAL		
QUANTITY: 1	HEAT TREAT: N/A	DRILLED AND COUNTERBORED HOLE DIAMETERS: $-.005" / +.015" [-0.13mm / +0.4mm]$		SIZE: D	DATE:	
		SolidWorks 500 MAXIMUM FINISH REQ'D ON SURFACES WITHOUT A SYMBOL		DRAWN BY: D.A.S.	DWG NO.:	
				CHECKED BY:	REV:	
				SCALE: 1:1	CTS-19A-T	
				SHEET		