

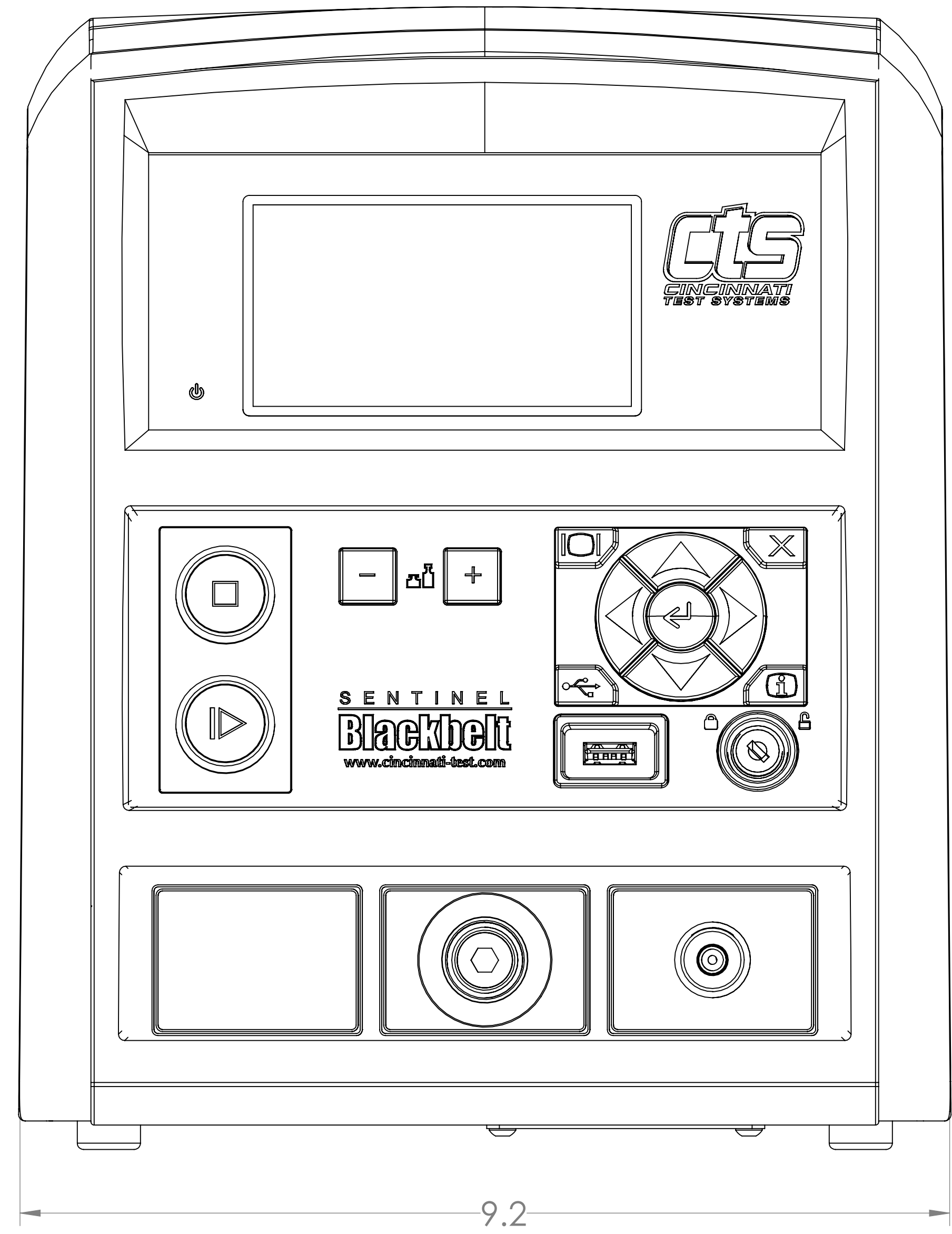

Overall Dimensions

configuration will vary

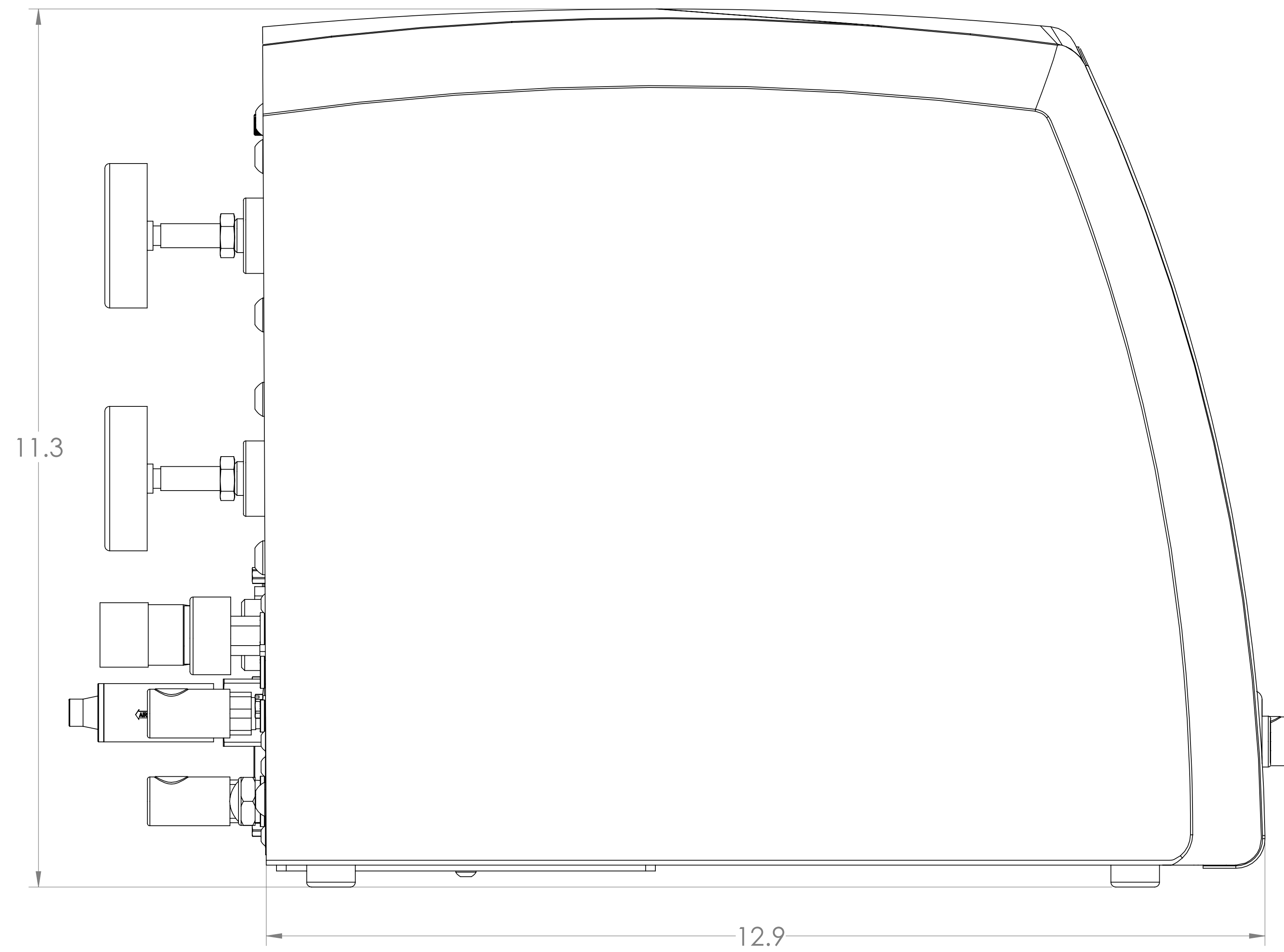
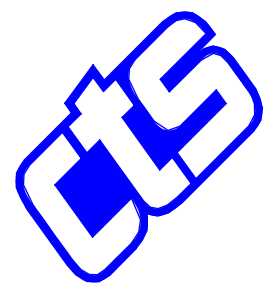

MATERIAL: -		UNLESS OTHERWISE SPECIFIED BREAK ALL SHARP CORNERS			 10100 PROGRESS WAY, HARRISON, OH 45030	
FINISH: -		TOLERANCES: 1 PLACE DECIMAL ± .050" [1.27mm] 2 PLACE DECIMAL ± .010" [0.25mm] 3 PLACE DECIMAL ± .003" [0.08mm] ANGULAR DIMS ± 0° 30'			CUSTOMER: -	
QUANTITY: -	HEAT TREAT: -	MANUFACTURER: CTS		SIZE: DATE: PART NUMBER: D 8/13/21 -		
JOB NUMBER: -		DRILLED AND COUNTERBORED HOLE DIAMETERS: -.005" / +.015" [-0.13mm / +0.4mm]		DESCRIPTION: Blackbelt		
		SolidWorks		SCALE: 1:1		
				SHEET 1 OF 3		

Component Locations

configuration will vary

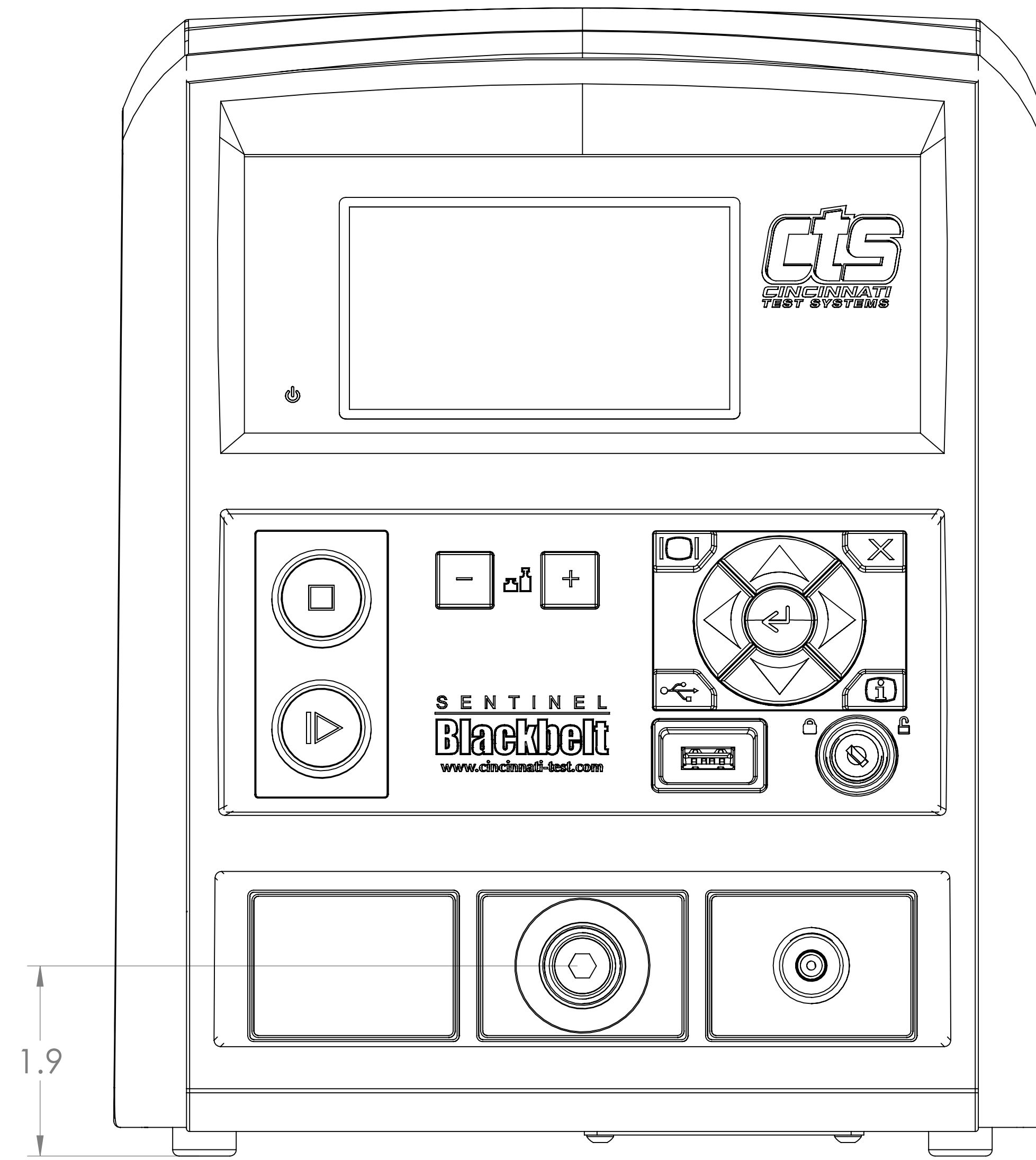
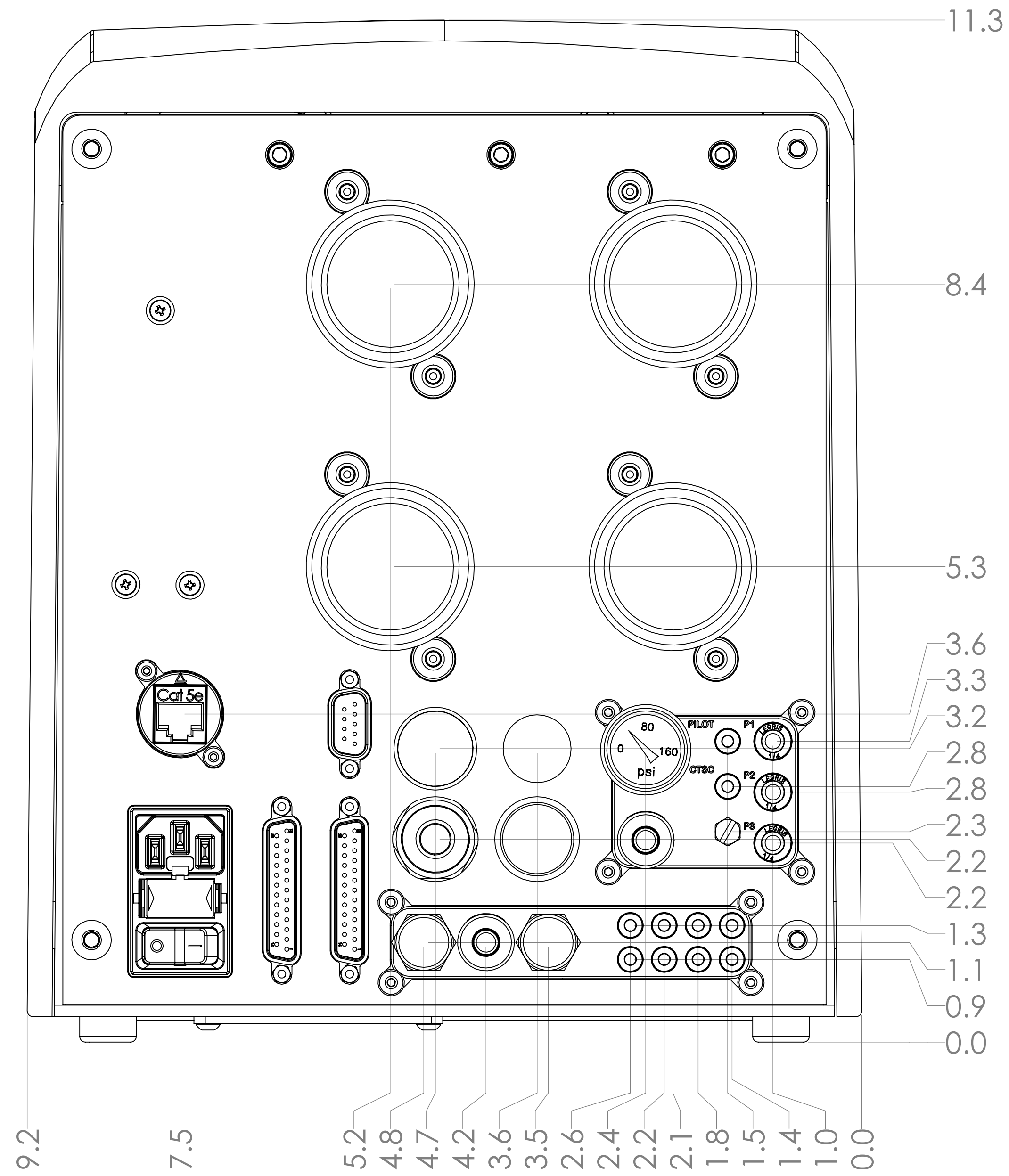

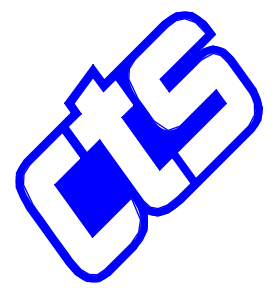

Single Test Port Shown

MATERIAL: — FINISH: — QUANTITY: HEAT TREAT: — — MANUFACTURER: CTS JOB NUMBER: —		UNLESS OTHERWISE SPECIFIED BREAK ALL SHARP CORNERS TOLERANCES: 1 PLACE DECIMAL ± .050" [1.27mm] 2 PLACE DECIMAL ± .010" [0.25mm] 3 PLACE DECIMAL ± .003" [0.08mm] ANGULAR DIMS ± 0° 30' ✓ INDICATES 125 200 MAXIMUM FINISH REQ'D ON SURFACES WITHOUT A SYMBOL DRILLED AND COUNTERBORED HOLE DIAMETERS: -.005" / +.015" [-0.13mm / +0.4mm]		CINCINNATI TEST SYSTEMS 10100 PROGRESS WAY, HARRISON, OH 45030 CUSTOMER: — SIZE: DATE: PART NUMBER: D 8/13/21 — DESCRIPTION: Blackbelt SCALE: 1:1 SHEET: 2 OF 3
		SolidWorks DRAWN BY: TS CHECKED BY: TS	REV: —	

Rubber Feet Locations

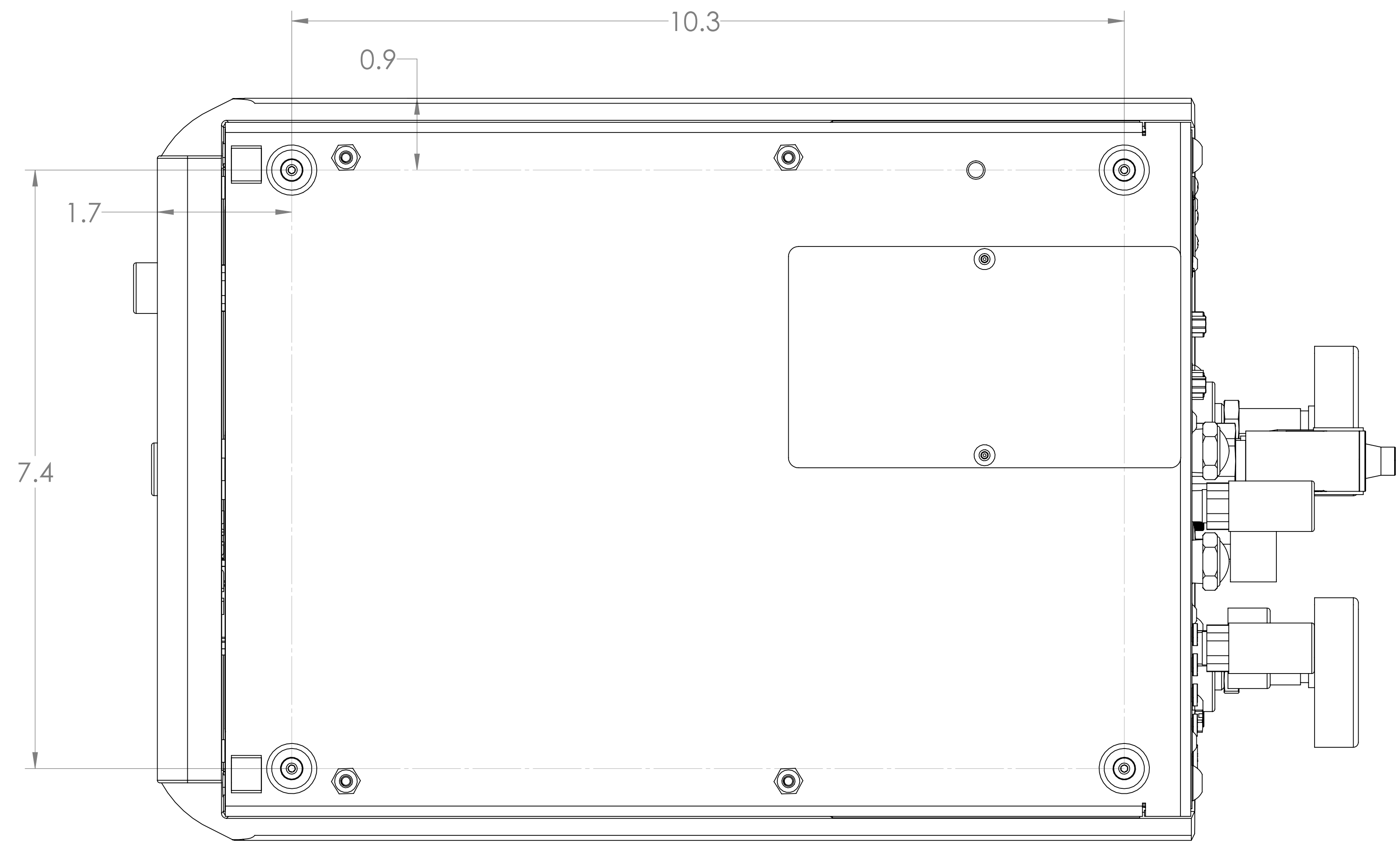
configuration will vary

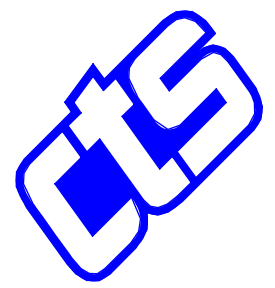

MATERIAL: -		UNLESS OTHERWISE SPECIFIED BREAK ALL SHARP CORNERS			 10100 PROGRESS WAY, HARRISON, OH 45030		
FINISH: -		TOLERANCES: 1 PLACE DECIMAL ± .050" [1.27mm] 2 PLACE DECIMAL ± .010" [0.25mm] 3 PLACE DECIMAL ± .003" [0.08mm] ANGULAR DIMS ± 0° 30'			CUSTOMER: -	SIZE: D	DATE: 8/13/21
QUANTITY: -	HEAT TREAT: -	✓ INDICATES 125 200 MAXIMUM FINISH REQ'D ON SURFACES WITHOUT A SYMBOL		DRAWN BY: TS	PART NUMBER: -		
MANUFACTURER: CTS		DRILLED AND COUNTERBORED HOLE DIAMETERS: -.005" / +.015" [-0.13mm / +0.4mm]		CHECKED BY: TS	DESCRIPTION: Blackbelt		
JOB NUMBER: -				SCALE: 1:1		REV: -	
						SHEET 3 OF 3	